

AF 220

HYDRAULIC
DRILL RIG



INTERNATIONAL

AF 220



THE PERFECT BLEND
OF TECHNOLOGY
AND PERFORMANCE

The AF 220 is one of the most prestigious machines with great performance. Its success is due to its characteristics of operative comfort, stability, reliability and, most importantly, productivity. This rig has been created for foundation piles with diameters from 450mm up to 2000mm and a depth up to 66 meters. The AF 220 is mounted on Caterpillar 330 D HHP excavator base with a Caterpillar undercarriage with extensible lower from 3m to 4,3m. IMT has analyzed every single detail in order to take the AF 220 model to the top of its market sector.





OPERATOR STATION

Besides the comforts available on the CAT base (adjustable seat, air conditioning, etc.) the rig controls in the cabin of the AF 220 are rationally distributed. The main controls, such as main winch, swing, rotary, crowd system, speed change, foot mast are operated by means of two main joysticks. It is possible to check verticality of the mast on the computer at any moment.

It also possible to install a different computer that supplies all the useful information pertaining to the rig and also gives the possibility of preparing a certificate relating to ground resistance.

This computer also shows the upper rotation position with respect to the rig. It is also possible to rotate the upper automatically to go back to the exact drilling position by using a button located on the upper rotation joystick.



BASE

The AF 220 uses a CAT 330D HHP base which has proved to be powerful and extremely reliable. Caterpillar installs on this base a CAT C9 type motor which is set to supply a power of 350 HP (261 KW) at 1800 rpm. Upon request, in order to utilize the power of the diesel to the most so as to guarantee maximum performance, IMT installs a load sensing hydraulic system, together with the Caterpillar original for pull down (as well as for services); this translates into extremely high productivity.



UNDERCARRIAGE

Manufactured by Caterpillar on the basis of our specifications. The crawler track undercarriage used on the AF 220 is the most that modern technology can offer in this category of machines.

- it has a central, "H" -type frame which can widen the lowers from 3 m (for transportation) to 4,3 m (working phase) and guarantees maximum operation in time and exceptional resistance to mechanical stress
- the lowers have a length of 5,87m and guarantee considerable stability in any type of ground
- it has a considerable traction force (500 KN effective) which allows easy movement even on the most difficult job sites





KELLY BAR

The standard Kelly bar is 4/46 (depth of 46 meters). The 4/48, 5/66, 4/35 and other types are also available. The square joint is available with sides of 150, 177, 200mm. All Kelly bars have automatic blocking patented by IMT; this allows the blocking of the telescopic elements in any position, permitting the transfer of pull down, pullback and torque very quickly.

ROTARY

The rotary of the AF 220 was conceived for unlimited duration. To the side of the rotary, two transmission groups, formed by hydraulic motor and reductor gear, move the two pinions. The rotary is capable of transmitting an effective torque of 260 kNm to the tool.

The operator can change speeds from inside the cabin; there are six different speeds to choose from. The working speeds vary from 7 to 27 rpm. During the drilling phase, the rotary has the entire power of the diesel at its complete disposal. The rotation speed and effective torque on the tool are continuously recorded by the on-board computer. With the rotary it is possible to supply a universal joint for the direct installation of casings.



OSIMO (AN) - ITALY - www.imtspa.com



ARTICULATION

The AF 220 utilizes a parallelogram type articulation. All the articulations of the machines use casehardened pins and bushings of large dimensions which guarantee maximum precision in time. The parallelogram type articulation offers the following advantages:

- possibility of moving the working axis accurately without losing the verticality of the mast
- possibility of working in a large range (essential when working with casing oscillator)
- correct anchoring of the mat by means of a hinge and tilting cylinder anchored at the top
- correct distribution of the machine weight in transportation configuration

MAST

It is built with high-resistance material, capable of supporting considerable stress with reduced weights (and therefore inertial force). It has great frontal (+5-15°) and lateral (+8°) range; this allows the machine to work in uneven grounds as well. The head of the mast is positioned at the top and has a "Y" shape for the pulleys of the main and secondary winches. The upper end is hydraulically articulated to change into the transportation phase. The lower extremity (articulated for transportation phase) is usually disassembled when working with casing oscillators of considerable size.





WINCHES

The main winch is positioned in the lower part of the mast, in front of the cabin so that the operator can constantly check the proper operation. During the lifting and lowering phase, the winch has the entire power of the diesel at its disposal; this gives the machine considerable speed and therefore maximum productivity. It has a hydraulic "down the hole" system which prevents the unwinding of the cable when the tool reaches the ground. Another system, called "free flow", allows the cable to advance in the drilling phase when the rotary advances. The on-board computer constantly displays pullback, speed and tool position.

A sound signal warns the operator of improper operation (example; if during the raising phase two elements of the Kelly bare inadvertently raised simultaneously). The main winch has a maximum pull back of 240 KN and a speed of 73 m/min.

As far as the secondary winch is concerned, the maximum speed is 85 m/min with a pullback of 120 KN.



CROWD SYSTEM

The crowd system of the AF 220 is positioned on the mast and it is used to transfer push and pull on the rotary. Thanks to the automatic blocking system patented by IMT, the push of 250 KN and pull of 390 KN are transferred directly to the tool.

AF 220

TECHNICAL DATA

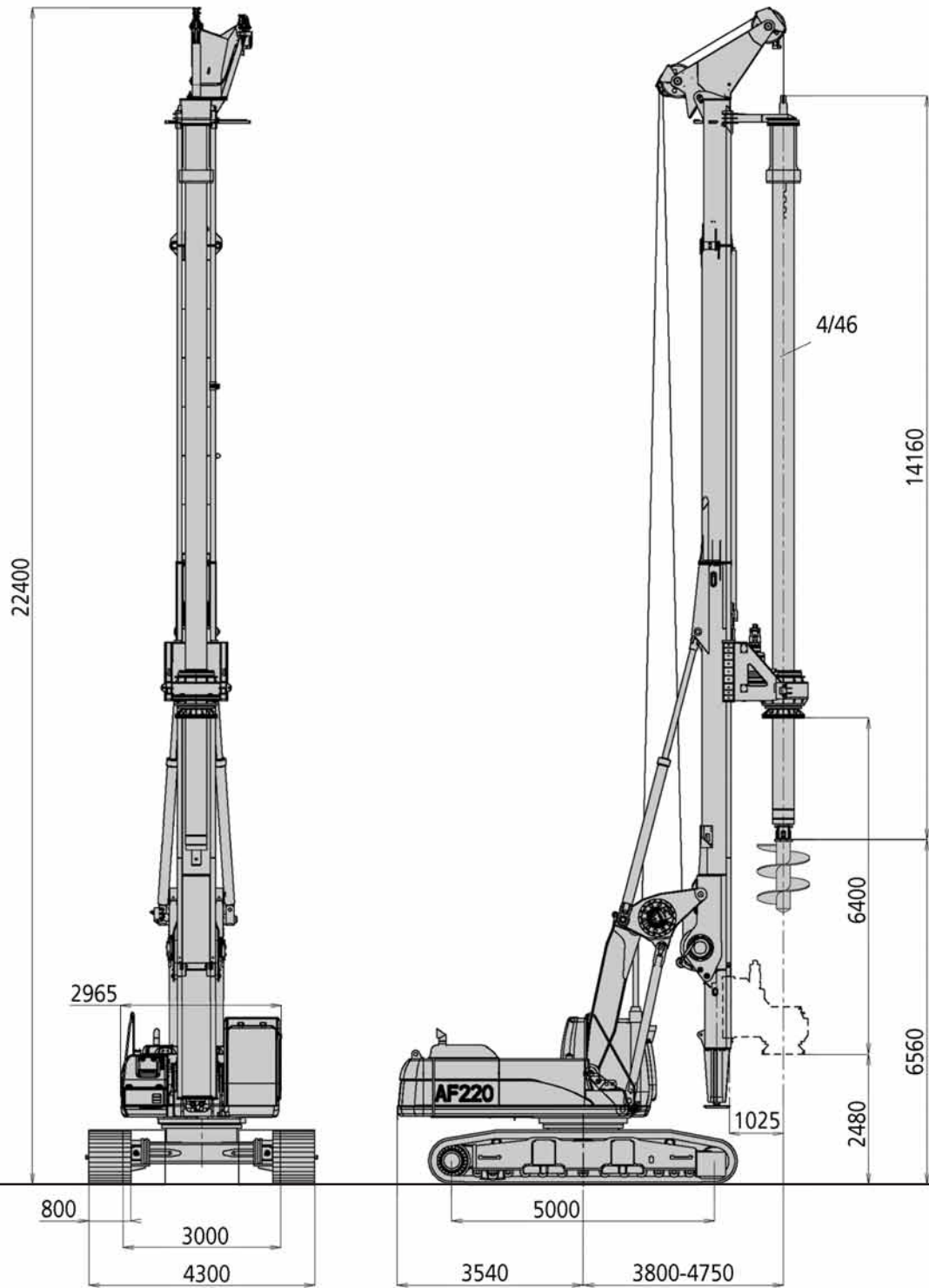

Base		Caterpillar 330D HHP		Caterpillar 330D HHP	
Undercarriage length / widening range / shoe	mm	CAT 5870/3000 - 4300/800		in	231/118 - 169/31,5
Engine type		CAT C9		CAT C9	
Power		261 KW (350 HP) @ 1800 rpm.		261 KW (350 HP) @1800 rpm.	
Rotary					
Installed torque	kNm	260		lbf ft	191770
Working speed	rpm	7 - 27		rpm	7 - 27
Discharge speed	rpm	45 - 110		rpm	45 - 110
Winches					
Main winch pull force	kN	240		lbf	53955
Main winch speed	m/min	73		ft/min	240
Main winch Cable diameter	mm	28		in	/
Auxiliary winch pull force	kN	120		lbf	26980
Auxiliary winch Speed	m/min	80		ft/min	262
Auxiliary winch Cable diameter	mm	22		in	/
Crowd system					
Kelly crowd push	kN	250		lbf	56205
Kelly crowd pull	kN	390		lbf	87680
Stroke	mm	6400		in	252
Mast					
Mast raking forward		5°		5°	
Mast side raking		±8°		±8°	
Mast raking backwards		15°		15°	
Pile max. diameter	mm	2000		in	79
Kelly bar					
Standard		4/46		4/46	
Options available		4/48 - 5/66		4/48 - 5/66	
Operating Weight w/standard kelly bar	t(metric)	67		lbs	147710

All technical data are indicatives and subject to change without notice

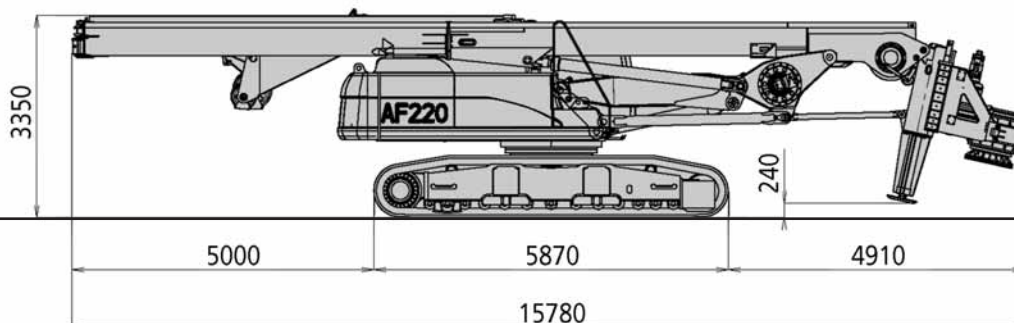

WORLDWIDE SALES AND ASSISTANCE NETWORK



IMT dealers, a global network at your service

IMT, like very few other companies in the field, has a global commercial and assistance network which is present in over 30 countries. From any part of the world, IMT clients know that they can always count on fast and efficient service.

Furthermore, since 1997 IMT drill rigs are sold and supported on the American market by Kelly Tractor, one of the biggest Caterpillar dealers in the world.

This is an important goal for the further reinforcement of the presence of IMT in international markets.



INTERNATIONAL

I.M.T. INTERNATIONAL S.p.A.
Industria Meccanica Trivelle
via D'Ancona, 39
60027 Osimo (AN) Italy
Tel. +39 071 723 341
Fax +39 0717 133 352
imt@imtspa.com
www.imtspa.com

