

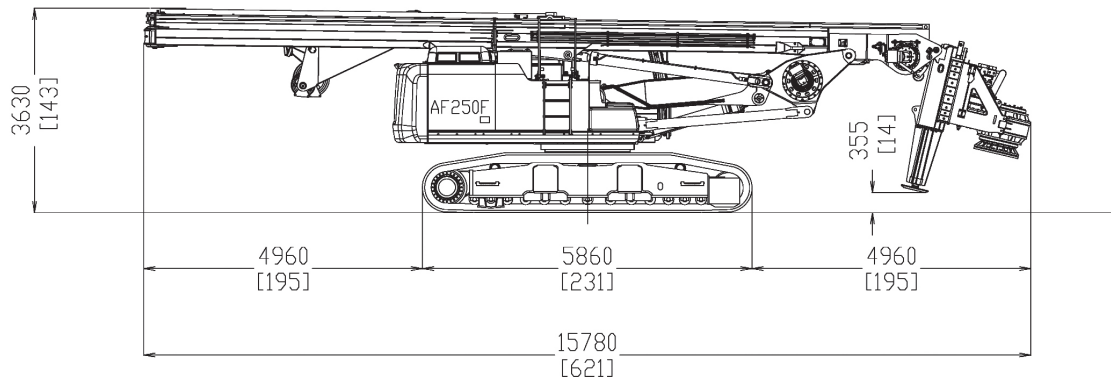

AF250 F



Base		Caterpillar 336F
Undercarriage length / widening range / shoe	mm	CAT 5860/3000 - 4270/720
	in	231/118 - 168/28,5
Engine type		CAT C 9 3 ACERT
Power	KW	241 (323 HP) @1550 rpm
Rotary		
Installed torque	kNm	260
	lbf ft	191770
Working speed	rpm	7 - 27
Discharge speed	rpm	45 - 110
Winches		
Main winch pull force	kN	240
	lbf	53955
Main winch speed	m/min	73
	ft/min	240
Main winch Cable diameter	mm	28
	in	/
Auxiliary winch pull force	kN	120
	lbf	26980
Auxiliary winch Speed	m/min	80
	ft/min	262
Auxiliary winch Cable diameter	mm	22
	in	/
Crowd system		
Kelly crowd push	kN	250
	lbf	56205
Kelly crowd pull	kN	390
	lbf	87680
Stroke (mm)	mm	6400
	in	252
Mast		
Mast raking forward		5°
Mast side raking		+ 8°
Mast raking backwards		15°
Pile max. diameter	mm	2000
	in	79
Kelly bar		
Standard		4/46
Options available		4/48 - 5/66
Operating Weight w/standard kelly bar	t (metric)	70
	lbs	154330

Measurements in working phase

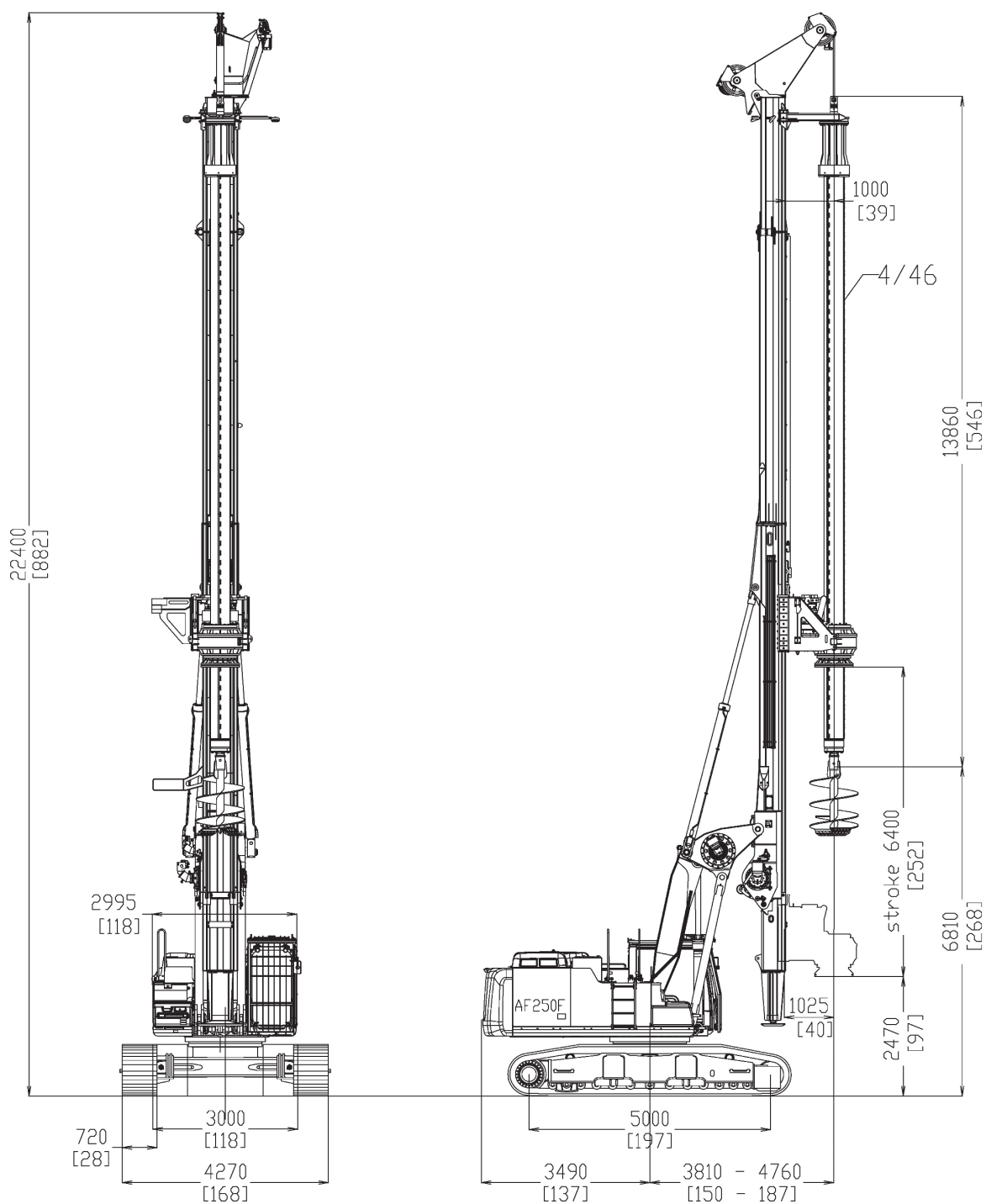

Via d'Ancona, 39 - 60027 Osimo (An) - Italy
 Tel. + 39 071 723341 r.a. - Fax + 39 071 7133352
 www.imtspa.com - imt@imtspa.com

All technical data are purely indicative and subject to change without notice.