

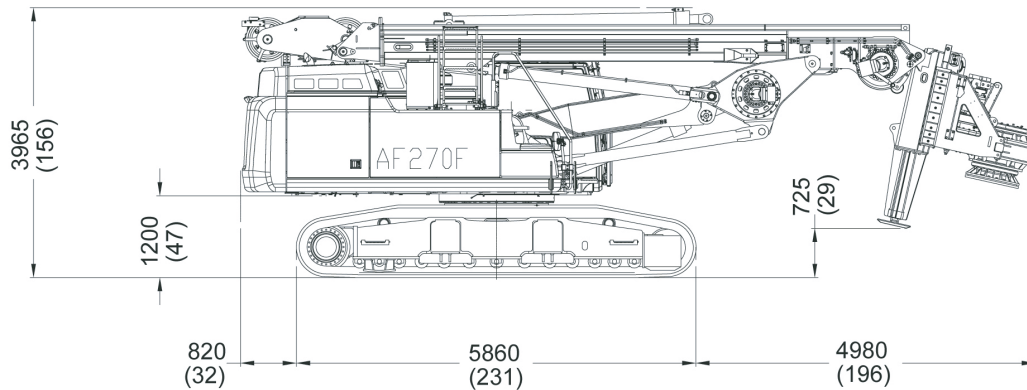

# AF 270F LCA

## Powered by CAT



<b>Base</b>		<b>CATERPILLAR 352F</b>
Undercarriage length / widening range / shoe	mm	<b>CAT 5860/3000 - 4270/720</b>
	in	<b>230.7/118 - 168/28,3</b>
Engine type		<b>CAT C 13 Acert Tier4 F</b>
Power		<b>322KW (432 HP) @1800 rpm</b>
<b>Rotary</b>		
Installed torque	kNm	<b>275</b>
	lbf ft	<b>202830</b>
Working speed	rpm	<b>8-30</b>
Discharge speed	rpm	<b>48-115</b>
<b>Winches</b>		
Main winch pull force	kN	<b>250</b>
	lbf	<b>56205</b>
Main winch speed	m/min	<b>73</b>
	ft/min	<b>240</b>
Main winch Cable diameter	mm	<b>28</b>
	in	<b>/</b>
Auxiliary winch pull force	kN	<b>120</b>
	lbf	<b>26980</b>
Auxiliary winch Speed	m/min	<b>80</b>
	ft/min	<b>262</b>
Auxiliary winch Cable diameter	mm	<b>22</b>
	in	<b>/</b>
<b>Crowd system</b>		
Kelly crowd push	kN	<b>300</b>
	lbf	<b>67445</b>
Kelly crowd pull	kN	<b>390</b>
	lbf	<b>87680</b>
Stroke	mm	<b>3000</b>
	in	<b>118</b>
<b>Mast</b>		
Mast raking forward		<b>5°</b>
Mast side raking		<b>+8°</b>
Mast raking backwards		<b>15°</b>
Pile max. diameter	mm	<b>2000</b>
	in	<b>79</b>
<b>Kelly bar</b>		
Standard		<b>4/20</b>
Options available		<b>4/17 - 5/33</b>
Operating Weight w/standard kelly bar	t	<b>69</b>
	lbs	<b>152120</b>

# Measurements in working phase

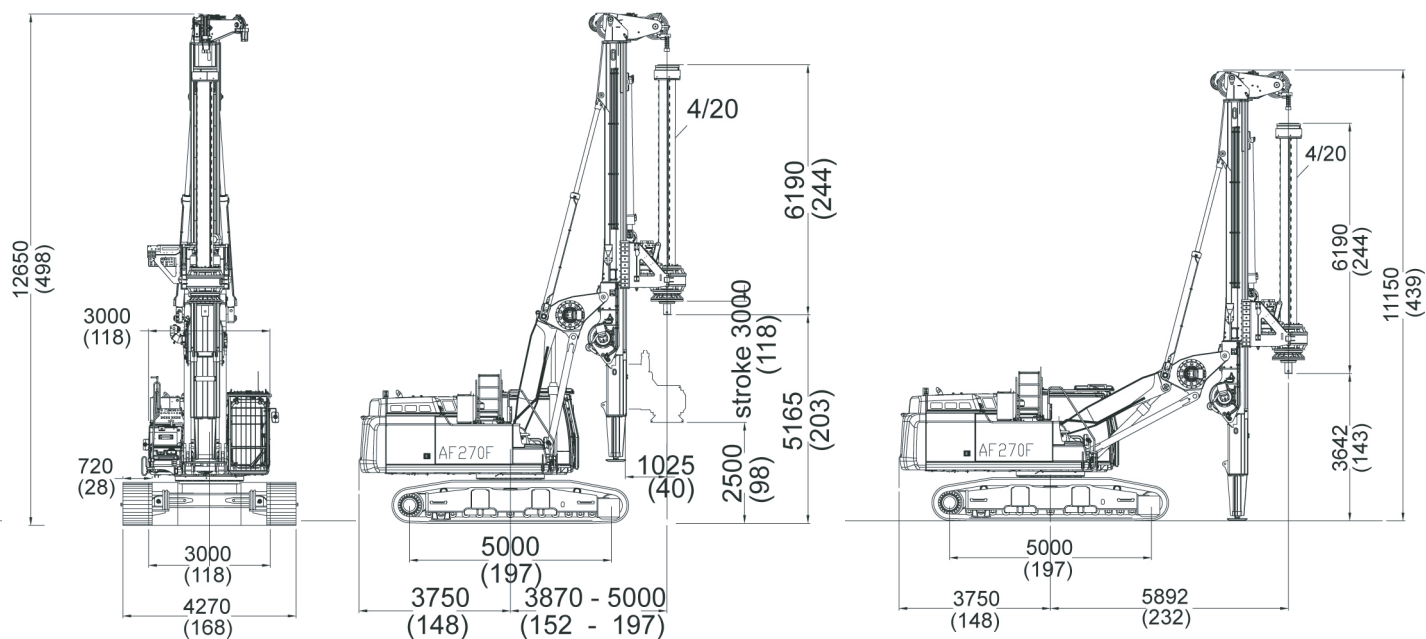

Purpose built Foundation Drilling Rig developed in cooperation with Caterpillar OEM Solutions Group



Via d'Ancona, 39 - 60027 Osimo (An) - Italy  
 Tel. + 39 071 723341 r.a. - Fax + 39 071 7133352  
[www.imtspa.com](http://www.imtspa.com) - [imt@imtspa.com](mailto:imt@imtspa.com)

All technical data are purely indicative and subject to change without notice.