

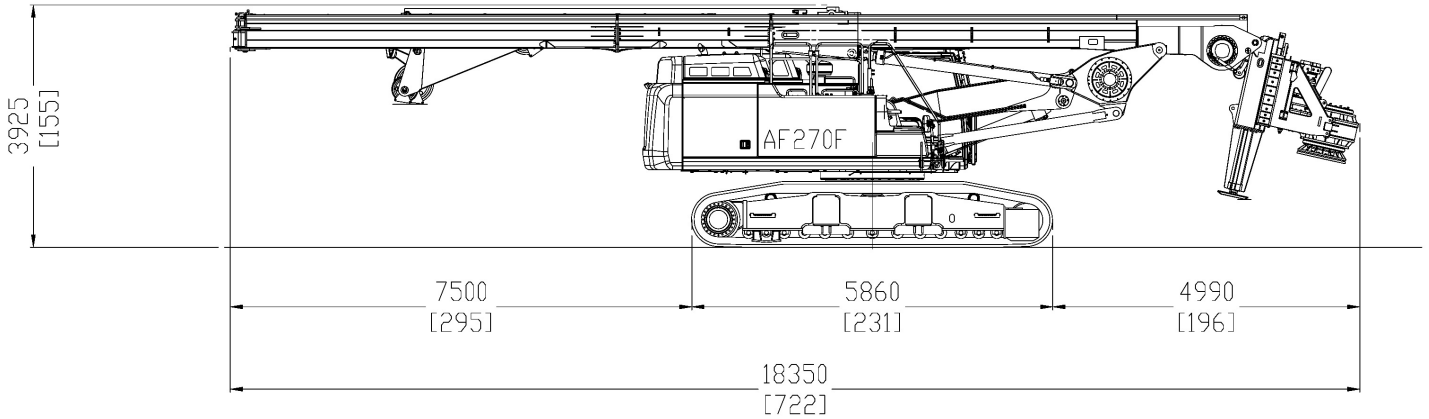

# AF 270 F

## Powered by CAT



|  |            |                            |
|--|------------|----------------------------|
| <b>Base</b>                                  |            | CAT 352 F                  |
| Undercarriage length / widening range / shoe | mm         | 5860/3000 - 4270/720       |
|  | in         | 230,7/118 - 168/28,3       |
| Engine type                                  |            | CAT C13 Acert Tier4 F      |
| Power  |            | 322 KW (432 HP) @ 1800 rpm |
| <b>Rotary</b>                                |            |                            |
| Installed torque                             | kNm        | 275                        |
|  | lbf ft     | 202830                     |
| Working speed                                |            | 8 - 30                     |
| Discharge speed                              |            | 48 - 115                   |
| <b>Winches</b>                               |            |                            |
| Main winch pull force                        | kN         | 250                        |
|  | lbf        | 56205                      |
| Main winch speed                             | m/min      | 73                         |
|  | ft/min     | 240                        |
| Main winch Cable diameter                    | mm         | 28                         |
|  | in         | /                          |
| Auxiliary winch pull force                   | kN         | 120                        |
|  | lbf        | 26980                      |
| Auxiliary winch Speed diameter               | m/min      | 80                         |
|  | ft/min     | 262                        |
| Auxiliary winch Cable diameter               | mm         | 22                         |
|  | in         | /                          |
| <b>Crowd system</b>                          |            |                            |
| Kelly crowd push                             | kN         | 300                        |
| Kelly crowd pull                             | lbf        | 67445                      |
|  | kN         | 390                        |
| Stroke                                       | lbf        | 87680                      |
|  | mm         | 6400                       |
|  | in         | 252                        |
| <b>Mast</b>                                  |            |                            |
| Mast raking forward                          |            | 5°                         |
| Mast side raking                             |            | +8°                        |
| Mast raking backwards                        |            | 15°                        |
| Pile max. diameter                           | mm         | 2000                       |
|  | in         | 79                         |
| <b>Kelly bar</b>                             |            |                            |
| Standard                                     |            | 4/46                       |
| Options available                            |            | 4/35 - 4/52 - 5/50 - 5/66  |
| Operating Weight w/standard kelly bar        | t (metric) | 76                         |
|  | lbs        | 167550                     |

# Measurements in working phase

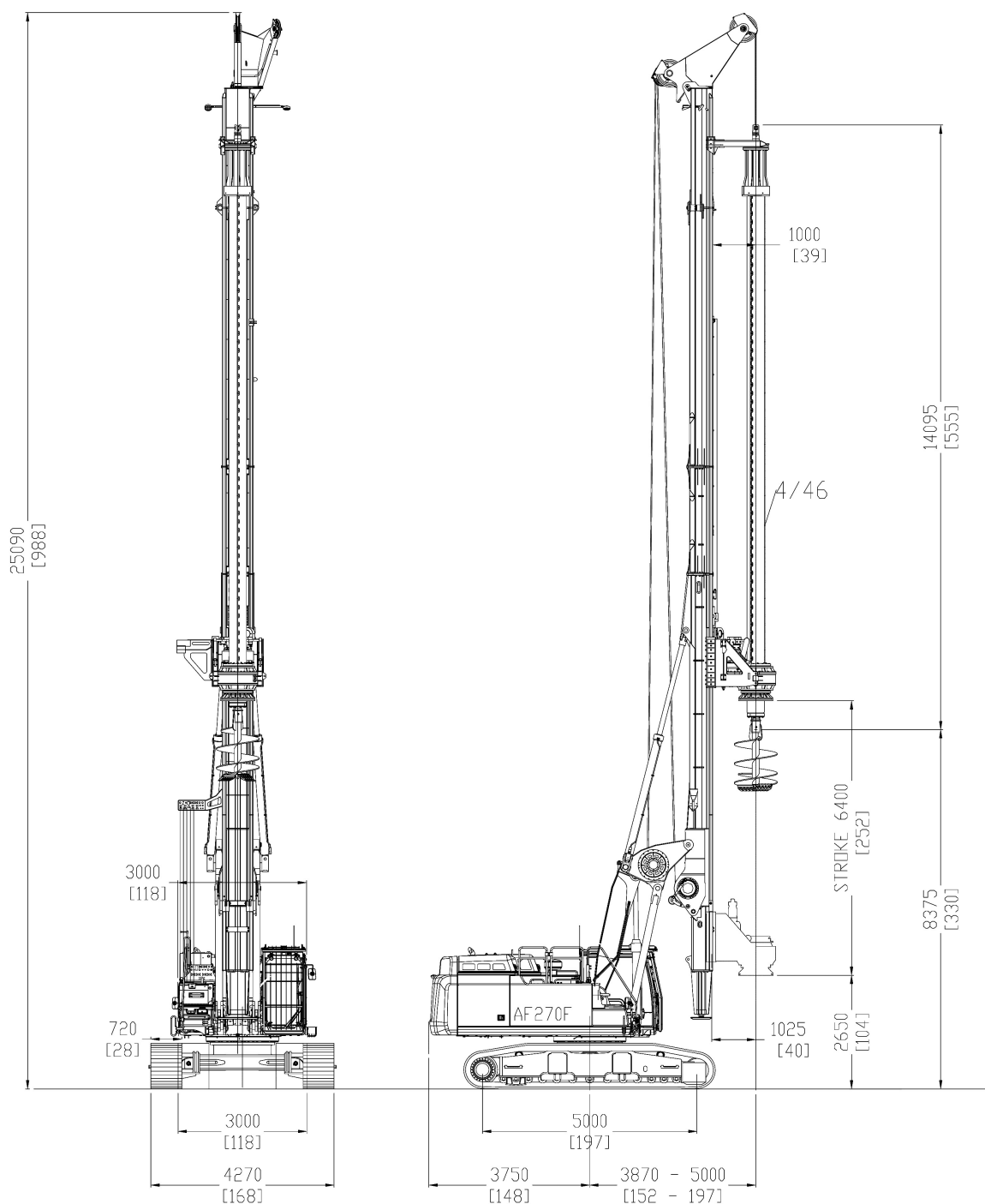

Purpose built Foundation Drilling Rig developed in cooperation with Caterpillar OEM Solutions Group



**Offices and Plant:**

Via d'Ancona, 39 - 60027 Osimo (An) - Italy  
 Tel. + 39 071 723341 r.a. - Fax + 39 071 7133352  
 www.imtspa.com - imt@imtspa.com

*All technical data are purely indicative and subject to change without notice.*