



939C

Hystat
Track-Type Loader



Cat® 3046T Engine

Gross horsepower	74 kW	99 hp
Flywheel horsepower	67 kW	90 hp

Bucket Capacities

GP Bucket	1.2 m ³	1.5 yd ³
MP Bucket	1.2 m ³	1.5 yd ³

Operating Weight

GP Bucket	9,484 kg	20,908 lb
MP Bucket	10,030 kg	22,113 lb

939C Track-Type Loaders

Offering rugged construction and outstanding reliability to allow you to maximize productivity.

Power Train

A powerful six-cylinder Cat® 3046 turbocharged engine and the new hydrostatic power train provide the power you expect from Cat 939C track-loaders. You also get the productivity you need to stay competitive.

Hystat system - a dual-path, closed-loop hydrostatic power train provides full powerturn capability, stepless speed range, dynamic braking and smooth modulation for steering and directional shifts.

pg. 4-6

Hystat Control

You'll be amazed how much dirt you can move with one hand using a 939C

- ✓ *Hystat track loader. A single joystick allows you to control speed, direction and steering, effortlessly.* **pg. 7**

Operator Station

Superior comfort awaits you day-in and day-out whether you opt for an open canopy or a loader equipped with a cab. Controls are ergonomically designed and well positioned, and armrests are fully adjustable for optimum comfort and productivity. *The 939C model is equipped with a new dash panel and*

- ✓ *vandalism protection guard.* **pg. 8-9**

Bucket & Lift Arms

Available general purpose or multi-purpose buckets increase machine versatility. Four-plate loader towers and large, solid-plate lift arms provide maximum strength and resistance to shock loads and loading stresses. Lift arms are reinforced with a crossmember to reduce torsional bending during loading. **pg. 10**

✓ *Outmaneuver every job you tackle.*

A single lever joystick control is all that is needed to control speed, direction and steering on Cat® 939C Hystat Track-type Loaders. Full powerturn capability is made possible by maintaining power to both tracks at any ground speed or turning radius. You'll find operating a loader of this size has never been easier or as much fun.

✓ *New feature*



Hydraulics

Powerful Caterpillar hydraulics provide exceptional strength for impressive breakout force and lift capacity. Two 7 micron filters keep dirt out to provide long component life. Matched hydraulic valves and loader linkages provide precise and lasting bucket control for superior load

- ✓ handling. *Hydraulic pump capacity has been increased by 50 percent to improve productivity. Lift cylinder diameter has been increased to provide 26 percent more lift force.*

pg. 4

Undercarriage

With soil conditions changing with each job you tackle, you need an undercarriage built rugged for long wear life and low owning and operating costs. That's why all 939C models are built with sealed and lubricated track. Sealed-in lubricant permanently coats the track pin, minimizing metal-to-metal contact and virtually eliminating internal pin and bushing wear.

- ✓ *Undercarriages have thicker recoil guarding for added impact resistance. New bolt-on, rear track guiding guards, further enhance rear guiding and provide extra protection against abrasive wear.*

pg. 11

Serviceability

✓ *Not only does the updated engine enclosure add to the impressive style of the 939C track loader, it also provides easier access to grouped service points. Scheduled Oil Sampling (S•O•S) valves are located on the engine oil filter and hydraulic filter housings for easy oil collection by your Cat dealer.*

pg. 12



Hystat Power Train System

Quick response and acceleration plus better maneuverability decrease cycle times and increase productivity

The Hystat system provides maximum performance everyday, no matter what your job application. The Hystat system features:

- **Full powerturn capability** at any ground speed or turning radius;
- **Stepless speed range** from 0 mph to maximum;
- **Smooth modulation** for steering and directional shifts;
- **Dynamic hydrostatic braking** provides full control of machine speed without using brakes;
- **Superior maneuverability** when working in tight areas;
- **Excellent controllability**, especially while operating in close quarters and
- **Load sensing**, which automatically adjusts speed and torque to match changing load conditions.

The Hystat system is a high pressure, dual path, closed loop hydrostatic power train system. Each track is driven by a separate hydraulic circuit consisting of one variable-displacement piston-pump, connected by Cat's XT-6 hose and couplings to a piston motor.

- 1 Hystat pumps.** Two high pressure, variable displacement piston pumps are attached directly to the engine flywheel housing. No U-joints or splitter box to service.
- 2 Track motors.** Two high pressure, 2-speed piston motors are mounted inboard of the main frame at the final drives.
- 3 Cat's XT hoses** are well respected for their strength and durability and are used to connect the pumps to the motors. O-ring face seals are used throughout the entire Hystat system and provide positive sealing for reliable, leak-free connections.
- 4 Two identical, vertically mounted hydraulic filters** are easily accessible and provide filtration for both the Hystat power train and implement systems.
- 5 Service brakes.** Hydrostatic (dynamic) braking through machine drive system using joystick control or center pedal.
- 6 Double reduction planetary final drives** provide high torque multiplication between the hystat motors and the drive sprockets. Drives are mounted independently of the track frames to isolate them from ground-induced shock loads.
- 7 Wet, multi-disc parking brakes** located between each hydraulic track motor and final drive are spring applied and hydraulically released. Automatically applied when the engine stops, or operator applied when the center pedal is fully depressed.
- 8 Neutral-start parking brake lever** disengages transmission and engages the parking brakes to prevent unintended machine movement.
- 9 Hydraulic oil cooler** is an air-to-oil type and provides cooling for the power train and implement oil.

Hydraulic System

Improved for increased productivity

- **50 percent increased pump flow** provides faster cycle times, resulting in more work done per hour
- **Larger lift cylinders** deliver 26 percent more lift force for tough loading applications
- **Improved bucket control** provides multi-function capabilities for fast truck loading and spreading applications
- **Reduced bucket control lever efforts** provide lower operator fatigue

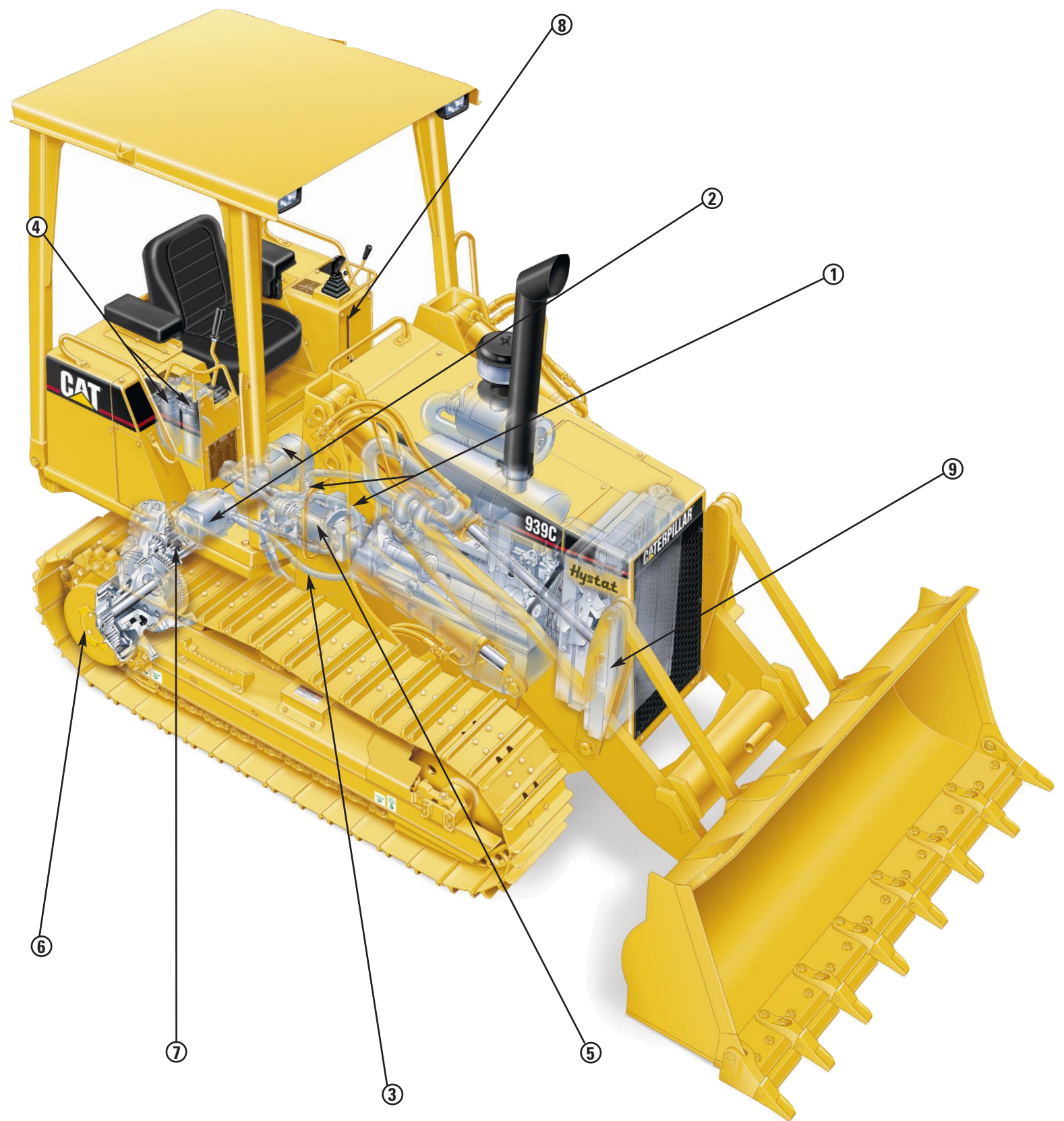

3046T Engine

Smooth, responsive power, excellent fuel economy and lasting reliability.



Caterpillar 3046T Diesel Engine.

Designed specifically for small to medium size earthmoving machines. The Cat six-cylinder 3046 turbocharged engine is inherently balanced, providing low vibration, superior performance, and exceptional responsiveness. Torque rise is 25 percent at 1400 RPM. The result is more lugging force, especially during heavy loads.

- **Direct injection fuel system** is adjustment free for reduced maintenance. High pressure fuel injection results in reduced fuel consumption and emissions.
- **Turbocharger** improves response and performance at low to medium engine speeds.
- **Spin-on oil and fuel filters** are vertically mounted and easily accessible for faster maintenance.
- **In-cylinder glow plugs** deliver dependable starts when operating in cold temperatures. Built-in temperature switch helps ensure lasting reliability.
- **Lubrication system** features an efficient, multiple-plate, water-cooled oil cooler to help prolong engine and lubricant life.
- **Cooling system.** A large diameter fan and full length, water-cooled cylinders, combined with excellent thermal efficiency, minimize heat rejection, prevent overheating and prolong engine life.
- **Cylinder head** uses replaceable valve seat inserts, valve guides and a high quality composition steel laminated head gasket.
- **Aluminum pistons** with a cast iron insert for increased durability under high compression loads. Pistons have two compression rings and an oil ring with a coiled expander.

Hystat Control

Steering, machine direction and speed are combined into one control for enhanced operator controllability, comfort and increased productivity.

The **joystick control** is simple and easy to understand. With it, you will control the direction, speed, and steering of your 939C Hystat track loader. The joystick is ergonomically designed to fit comfortably in the palm of your hand. Control effort is minimal, so much so that you might find yourself using your fingertips.

Direction/speed

- **Forward movement.** As you move the joystick forward, the machine moves forward, traveling faster as the joystick is moved further forward from the center position.
- **Reverse movement.** When you move the joystick back, the machine will move in reverse, again traveling faster the further the joystick is moved back from the center position.
- **Stopping.** The easiest way to stop the machine is to return the joystick to the center position. The joystick is spring-loaded and will return to neutral by itself. You may also stop the loader by pressing the center brake pedal all the way down with your foot.
- **Turtle/rabbit switch.** In turtle mode, the drive motors are fixed in the maximum torque position (working mode). Switching to rabbit mode changes the drive motors to a higher speed setting (roading mode). To activate the turtle/rabbit mode, simply use the toggle switch located on top of the joystick.



Steering

- **Right/left movement.** With the machine moving in forward or reverse, moving the joystick to the right results in the machine turning to the right; moving the joystick to the left causes the machine to move to the left. The more the joystick is moved to the left or right, the tighter the turn.

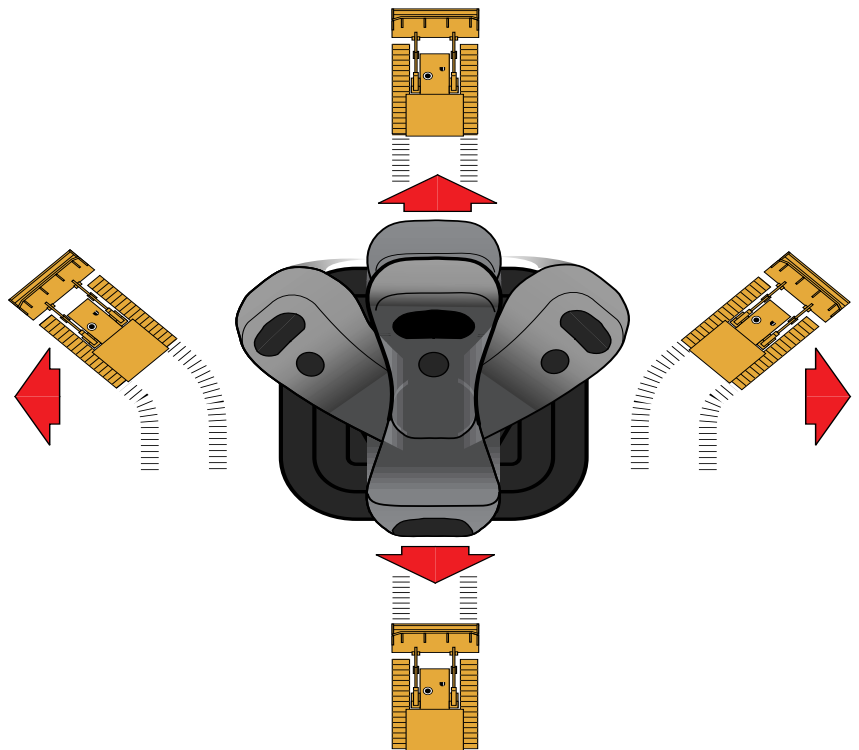

Operator Station

Ergonomically designed for your maximum comfort and productivity.

Take the opportunity to work comfortably and productively, day-in and day-out. Whether you equip your loader with an open canopy or an optional cab, you'll find thoughtfully positioned controls and a variety of other convenience features.

- 1 Hystat joystick control** gives you the power to control steering, direction and speed all with your left hand. Easily switch from turtle/rabbit mode with the toggle switch located on top of the joystick. Activate the horn by pressing the button beneath the turtle/rabbit toggle switch.
- 2 Joystick hold control** holds the joystick in any forward/reverse position, freeing the operators left hand.
- 3 Hystat center pedal** may be used to either slow down or stop the machine. Adjustable foot rests provide a great place for your feet to relax while working.
- 4 Single lever lift and tilt control** improves efficiency. Needle bearings on all major pivot points and valve spools with precision metering help ensure precise, lasting control.
- 5 Governor control.** High to low setting allows you to set engine speed at the desired RPM. Hystat loaders can be operated at any RPM.

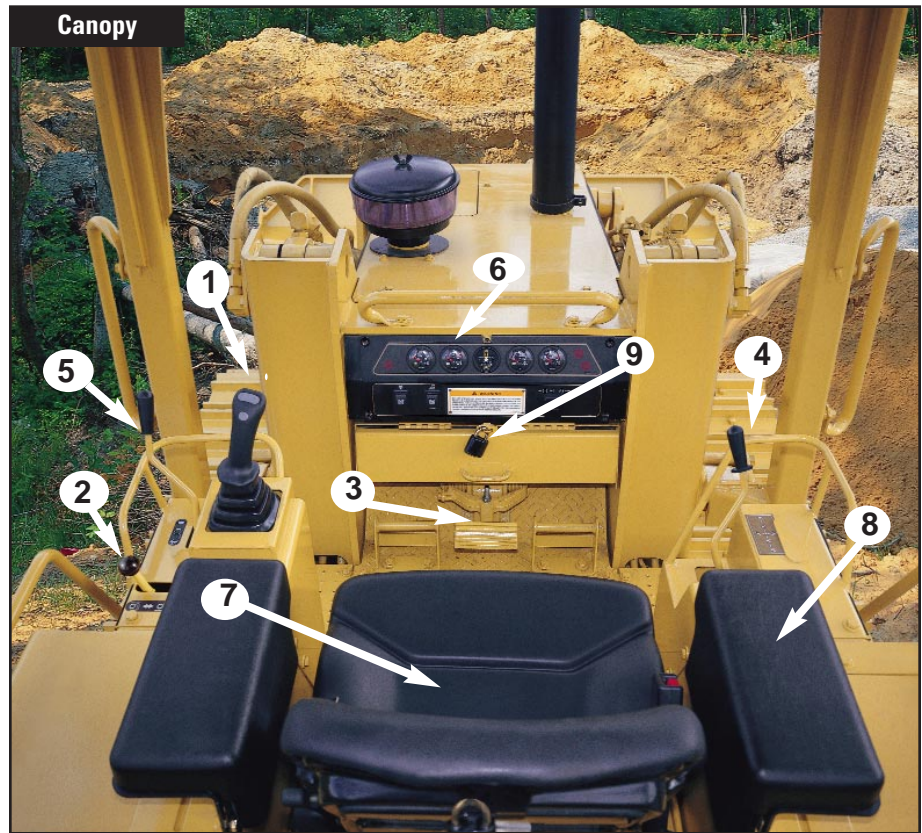

- 6 Dash panel** has five individual, analog gauges, providing fluid level and temperature information at a glance. All gauges are back-lighted.
- 7 A suspension seat** is standard on all 939C track loaders and is equipped with a seat belt and an adjustable backrest.

- 8 Armrests are adjustable** fore and aft, as well as up and down to best suit your preferred operating position.
- 9 Vandalism protection guarding** on canopy models folds down under the dash for storage, and is raised over the dash and padlocked when needed.



Ease of Operation - All major machine work functions can be accomplished with just two hands.

Reduced Operator Fatigue - Low control lever efforts help increase operator productivity each day. Day after day.

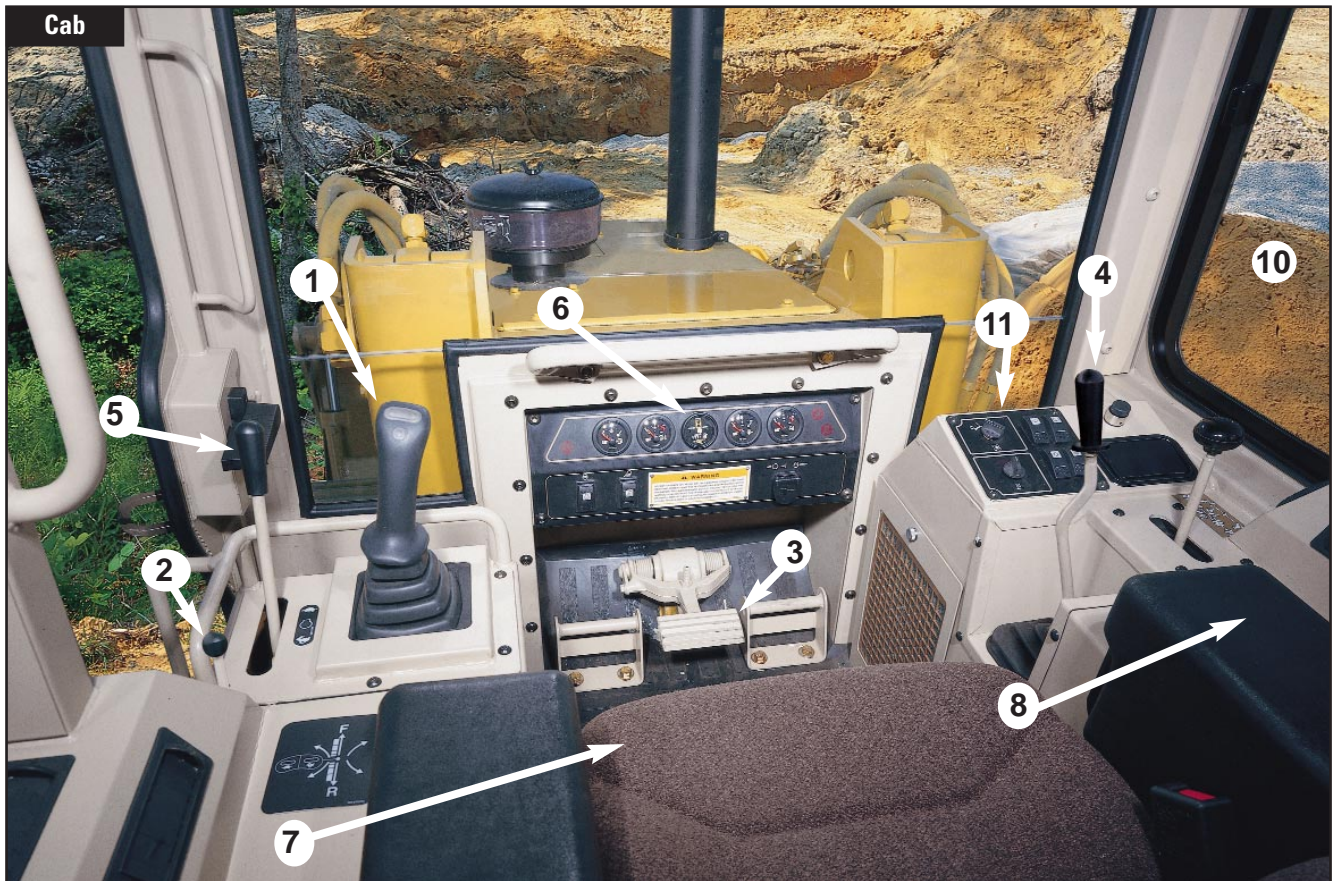

The pressurized cab is sealed to keep dust out and sound to a minimum, resulting in a quiet working environment. Nine adjustable vents keep air circulating and improve the cab's heating, optional air conditioning, and defrost/defog capabilities.

10 Tinted windows. A continuous, three-piece glass windshield and a large, single-piece door glass provide excellent visibility to the work site. Large, sliding right and rear side windows provide excellent flow-through ventilation.

11 Control console is back-lighted and contains controls for cab temperature, fan speed, the front/rear window washers, and two-speed wipers. A cigarette lighter and ashtray are also included.

12 An optional Caterpillar Contour Series seat, with a retractable seat belt, is the premium seat option and is designed for maximum comfort and fully-adjustable support. Ergonomically shaped seat cushions reduce pressure on the lower back and thighs, while allowing unrestricted arm and leg movement. Contour Series seats are available in cloth for use in cab, or vinyl when used in open canopy.

Other cab conveniences include:

- Radio ready factory installed components, including speakers, an antenna, and all wiring/brackets
- Tie-downs for secure lunch box storage
- Sunvisor
- Rearview mirror
- Dome light
- Coat hook



Buckets and Lift Arms

Designed and built for unmatched versatility, durability, and strength.

Rugged construction along with powerful, matched hydraulics provide excellent breakout force and lift capacities for maximum production capabilities and load handling.

1 General-purpose bucket. Designed for excavating, loading and general purpose work. Wide, large capacity means excellent track coverage and increased production potential.

2 Multi-purpose bucket. Designed for excavating, loading, stripping and cleaning up debris. Provides maximum versatility and strength to handle the toughest jobs.

3 Bolt-on cutting edge segments are reversible and extend the wear life of the bucket.

4 Bolt-on Corner Guard System protects the edges for long term wear.

5 Backdrag edge adds grading capability to extend machine versatility.

6 Solid-plate lift arms provide strength and durability for excellent lift and breakout capacities.

Replaceable bottom plates increase the buckets' service life.

High bucket rackback angle retains material for increased efficiency.

Sealed loader linkage increases all linkage lube points to 50 Service Meter Hours.

Cat's XT-3 hoses meet critical strength and flexibility demands for increased reliability.

Cylinders. Large diameter hydraulic cylinders provide powerful force. Precision finished rods for minimal seal wear.

Four-plate loader tower resists shocks and loading stresses.

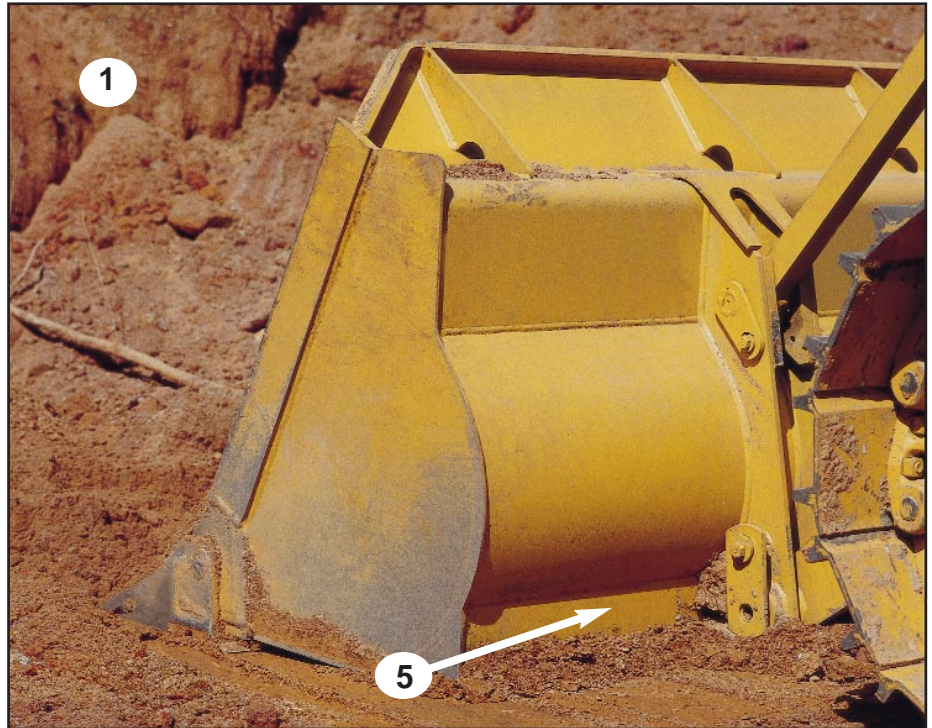

Undercarriage

Components designed to provide you with maximum performance and wear life.

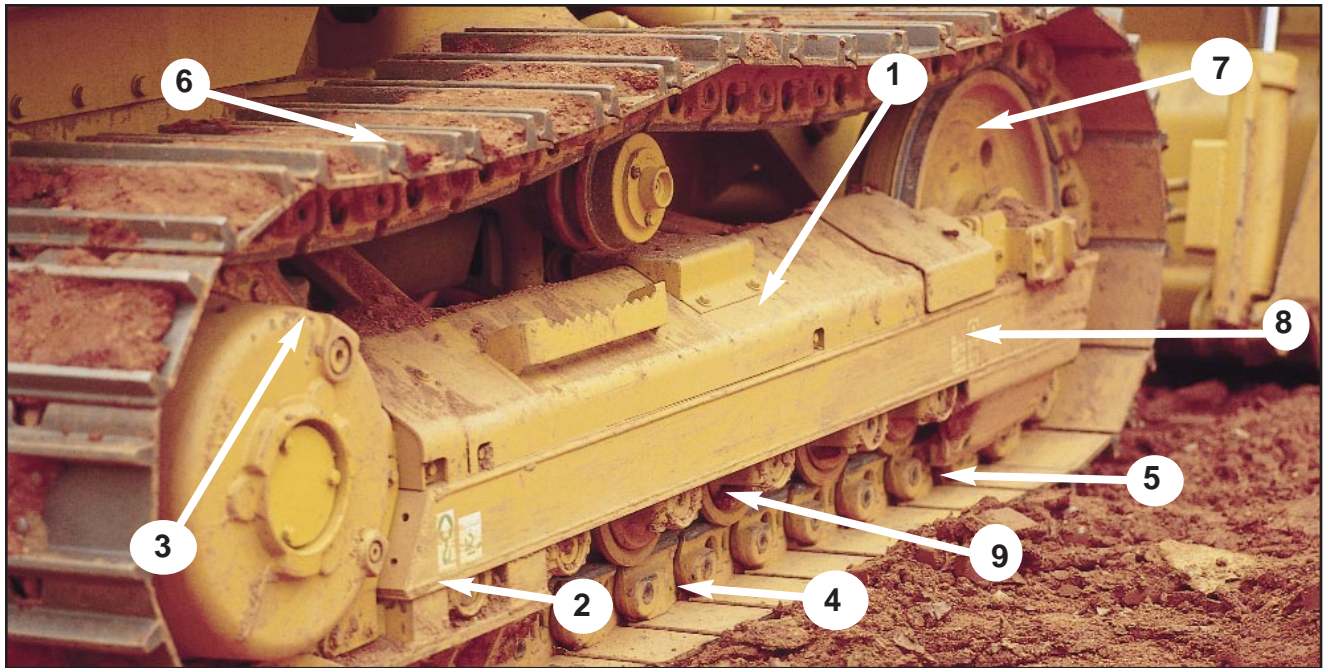

Undercarriage is designed and built by Caterpillar for long wear life and low owning and operating costs.

Standard undercarriage

- A general purpose undercarriage that performs well in applications with firm underfoot conditions.
- Standard shoe width: 406 mm (16") double grouser.
Optional shoe width: 460 mm (18") double grouser.

1 Full length recoil guarding with sprocket guards and wipers assists in reducing material buildup and helps prevent material from entering the undercarriage system for maximum component wear life.

2 Front and rear track guiding guards provide additional protection from abrasive material. Rear guards are a bolt-on design making installation and removal easy.

3 Segmented sprocket allows replacement of sprocket teeth without splitting the track, reducing downtime and lowering maintenance costs.

4 Split master link features strong, serrated two half links for easy track removal. No driving pin is needed.

5 Sealed and Lubricated Track eliminates internal pin and bushing wear for longer wear life. Strong, strutted links provide increased strength and service life.

6 Track shoes are made from heat-treated steel for strength and durability.

7 Idlers. Heat treated idlers are sealed and lubricated to provide long life.

8 Box-section track roller frame provides maximum structural integrity for increased roller frame alignment, and reduces relative motion.

9 Track rollers. Sealed and lubricated rollers eliminate internal wear for longer service life. Sequenced single and double flange rollers provide superior track link alignment.

Serviceability

More access and fewer maintenance requirements add up to unparalleled ease of service.

Zerk lube fittings allow easy lubrication of the loader linkage pivot pins to provide long life and maintain tight linkage.

Removable engine enclosure has a built-in grip handle and provides access to vertically mounted, spin-on engine oil and fuel filters, S•O•S valve, and fuel priming pump.

Engine oil dipstick, oil fill and radiator fill is easily accessed through a hinged and lockable panel on top of the hood.

Combined power train and hydraulic oil filters are vertically mounted for cleaner changes and are easily accessible by removing the rear panel. An S•O•S valve is conveniently installed on the filter base for sampling power train oil.

Ground level sight gauge allows easy check of hydraulic oil level.

Fuel/water separator is accessed easily through a hinged door located at the rear of the machine.



Total Customer Support

When you purchase Cat equipment, you also get Caterpillar's and your Cat dealer's total commitment to customer support.



Your Cat dealer offers a wide range of services that can be set up under a customer support agreement when you acquire a 939C Hystat loader or any other Caterpillar equipment. The dealer will help you choose a plan that can cover everything from machine and attachment selection to replacement intervals. The bottom line is you get the best return on your machine investment.

Selection. Your Cat dealer can help you make detailed comparisons of machines you are considering before you buy. You can compare things like expected component life, the cost of preventive maintenance and the true cost of lost production. You can get precise answers to these questions from your Cat dealer.

Easy financing. Consider all the flexible financing options your Cat dealer offers as well as day-to-day operating costs. Whether it's rental, leasing, or purchase, your Cat dealer can meet your needs.

Maintenance. Choose from your Cat dealer's wide range of maintenance services at the time you acquire your 939C Hystat loader. Repair option programs guarantee the cost of repairs up-front. Diagnostic programs such as S•O•S Oil Analysis and Technical Analysis help you avoid unscheduled repairs that can cost you unnecessary time and money.

A Customer Support Agreement can enhance the value of your 939C Hystat loader by lowering your costs per unit of production and puts your Cat dealer's superior support capabilities to work for you. They are flexible and customized to your individual needs, whether for a single machine or a whole fleet. Ask your Cat dealer for details.

Product support. Nearly all the parts needed to support the 939C Hystat loader are already available at your dealer's parts counter. Cat dealers use a world-wide computer network to find in-stock parts to minimize downtime.

Replacement. Throughout the life of your 939C Hystat, your Cat dealer can help you evaluate the cost involved with repairing, rebuilding or replacing. You can be assured that the choice you make will be the right one.

Engine

Four-stroke cycle, in-line six cylinder Cat 3046 turbocharged diesel engine.

Ratings at 2400 RPM*	kW	HP
Gross power	74.6	100
Net power	67.9	90

The following ratings apply at 2400 RPM when tested under the specific standard conditions for the specified standard:

Net Power	kW	HP	PS
Caterpillar	67.9	91	—
ISO 9249	67.9	91	—
EEC 80/1269	67.9	91	—
SAE J1349	67.1	90	—
DIN 70020	70.1	94	95

Dimensions

Bore	94 mm	3.7 in
Stroke	120 mm	4.7 in
Displacement	5 liters	305 in ³

*Power rating conditions

- based on standard air conditions of 25°C (77°F) and 99 kPa (29.32 in Hg) dry barometer
- used 35° API gravity fuel having an LHV of 42 780 kJ/kg (18,390 Btu/lb) when used at 30°C (86°F) [ref. a fuel density of 838.9 g/L (7.001 lb/U.S. gal)]
- net power advertised is the power available at the flywheel when engine is equipped with fan, air cleaner, muffler and alternator
- no derating required up to 2300 m (7500 ft) altitude

Engine Performance Curve

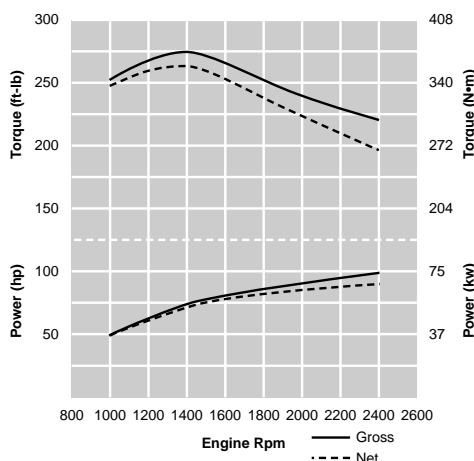

Features

- turbocharger
- direct-injection fuel system with individual adjustment free injection pumps and valves
- electric fuel shutoff solenoid
- one-piece head with two valves per cylinder
- composition steel laminated head gasket
- aluminum pistons with cast iron insert, two compression rings and one oil ring
- high carbon steel forged iron connecting rods
- steel-backed aluminum bearings with lead-tin overlay
- seven main bearing forged crankshaft, fully counterweighted and hardened
- oil pump, gear driven from the crankshaft
- piston cooling jets
- multi-plate, water-cooled oil cooler
- belt-driven water pump
- conventional core radiator with 533 mm (21") fan
- dry-type air cleaner with primary and secondary elements and a restriction indicator
- 12-volt direct-electric, gear reduction starter with terminal shielding
- 55-amp alternator standard with ROPS canopy; 90-amp alternator standard with optional cab
- 12-volt, 900 cca, group 31, maintenance free battery with disconnect switch
- in-cylinder glow plugs with built-in temperature switch
- vertically mounted, spin-on oil and fuel filters

Hystat Transmission

Dual-path, hydrostatic drive provides infinitely variable speeds up to 9.0 km/h (5.6 mph), forward or reverse.

Features

- each track is driven by a separate variable-displacement piston pump and motor combination
- drive pumps: two variable-displacement, slipper-axial piston pumps mounted tandem-style to engine flywheel housing
- track motors: two 2-speed, link-type piston motors mounted inboard of main frame at the final drives
- full flow filtering of hydrostatic charge system oil
- relief valve settings: 42 000 kPa/420 bar/6100 psi
- charging pumps: two gear-type, one per drive circuit

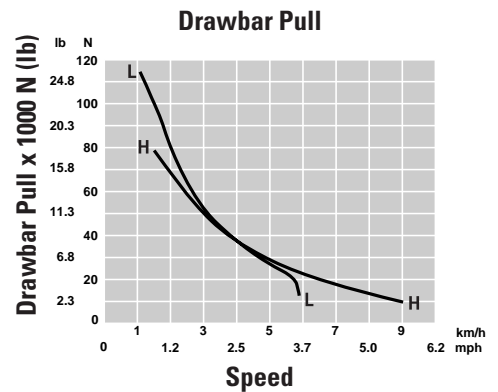

Implement Hydraulics

Open-centered, parallel system. System is completely sealed.

Implement system, gear-type pump

Output at rated engine RPM and 6895 kPa (1000 psi)	133 liters/min	35 gpm
Relief valve setting (main)	19 820 kPa	2875 psi

Cylinders,

Lift, double acting: bore and stroke	114 x 607 mm	4.5 in. x 23.9 in.
Tilt, double acting: bore and stroke	102 x 622 mm	4.0 in. x 24.5 in.

Hydraulic cycle time

Raise	5.6 seconds
Dump	2.4 seconds
Lower, empty, float down	2.9 seconds
Total	10.9 seconds

Bucket controls

Lift circuit (raise, hold, lower, float) automatic kickout in raise can be activated on/off by switch.

Tilt circuit (tilt-back, hold, dump, regen dump) automatic bucket positioner-adjustable to desired digging angle.

Features

- large-capacity single section gear pump
- lines are steel tubing and high pressure XT-3 hose with o-ring face seals at connections
- system sealed to keep out wear-causing dirt
- protected by two 7 micron filters which help prevent foreign material from entering reservoir
- standard two-valve hydraulics for lift and tilt
- optional three-valve hydraulics for lift, tilt and MP bucket
- optional four-valve hydraulics for lift, tilt, MP bucket and rear implement
- spring-centered, double acting valves with precision metering
- needle bearing yokes on all major pivot points
- single lever control for lift and tilt
- automatic bucket positioner and lift kick out
- multi-function capability for fast truck loading and material spreading applications

Final Drives

Hystat System Features

- double-reduction, with outboard planetary gear set
- mounted independently of track frames to isolate them from machine weight and ground-induced shock loads
- externally mounted for easy maintenance and service

Weights

(Approximate)

	kg	lb
GP	9,484	20,908
MP	10,030	22,113

* Operating weight with OROPS, 16" track, bucket, recommended counterweight, operator, no teeth/segments, fully fueled.

Steering and Braking

Hystat System Steering Features

- single lever steering and direction control
- moving control lever left or right slows that track, causing machine to turn smoothly in that direction with full power to both tracks
- full lever movement left or right causes that track to stop
- hydrostatic steering eliminates steering clutches and brakes, eliminates adjustments too

Hystat Service Brake Features

- hydrostatic (dynamic) braking through machine drive system using transmission control lever or center brake pedal

Hystat Parking Brake Features

- wet, multi-disc brakes located between each hydraulic track motor and final drive
- spring applied, hydraulically released by oil pressure from hydrostatic charge circuit
- automatically applied when the engine stops, or in the event of transmission hydraulic oil pressure loss
- operator applied when the center pedal is fully depressed, or when the parking brake lever is in the "park" position
- Hystat control system meets SAE J1026-APR90.

Service Refill Capacities

Hystat System Capacities

	Liters	Gallons
Fuel tank	157	41.4
Crankcase and filter	13	3.4
Final drives each side	14.7	3.9
Cooling system	21	5.5
Hydraulic tank	56.8	15

Cab

Caterpillar cab and Rollover Protective Structure (ROPS).

Features

- modular design
- tinted windows
- sliding right and rear windows
- electric wiper/washer controls
- nine adjustable ventilation ducts with three-speed fan
- front and rear wipers and washers
- sunvisor
- dome light
- speakers, antenna, wiring and radio bracket
- cigarette lighter and ashtray
- cloth suspension seat and headrest
- 3" seat belt
- coat hook
- key lock
- insulated rubber floormat
- meets Falling Object Protective Structure (FOPS) criteria SAE J395a, SAE J231-JAN81, and ISO 3449-1992.

Canopy

Rollover Protective Structure (ROPS). ROPS canopy is required in U.S.A.

Features

- vinyl suspension seat
- sound suppression headliner
- 3" seat belt
- wide angle rearview mirror
- meets ROPS criteria SAE J1040-MAY94 and ISO 3471-1994
- meets Falling Object Protective Structure (FOPS) criteria SAE J395a, SAE J231-JAN81, and ISO 3449-1992.

Undercarriage

Rebuildable, deep hardened steel components.

	Standard
Shoe width	406 mm (16")
Length of track on ground	2145 mm (84.4")
Track gauge	1549 mm (61")
Ground contact area	17,415 cm ² (2700 in ²)
Ground pressure *	53.67 kPa (7.79 psi)
Number of rollers (each side)	6
Number of shoes (each side)	37

* Equipped with general purpose

Features

- Sealed and Lubricated Track
- hydraulic track adjusters
- box section track roller frames
- bolt-on rear track guiding guards
- full length recoil guarding with sprocket guards and wipers
- serrated, two-piece split master link
- double-grouser shoes
- segmented sprocket
- sealed and lubricated rollers and idlers

Loader Dimensions

Approximate dimensions are applicable to all 939C Hystat Track-Type Loaders.

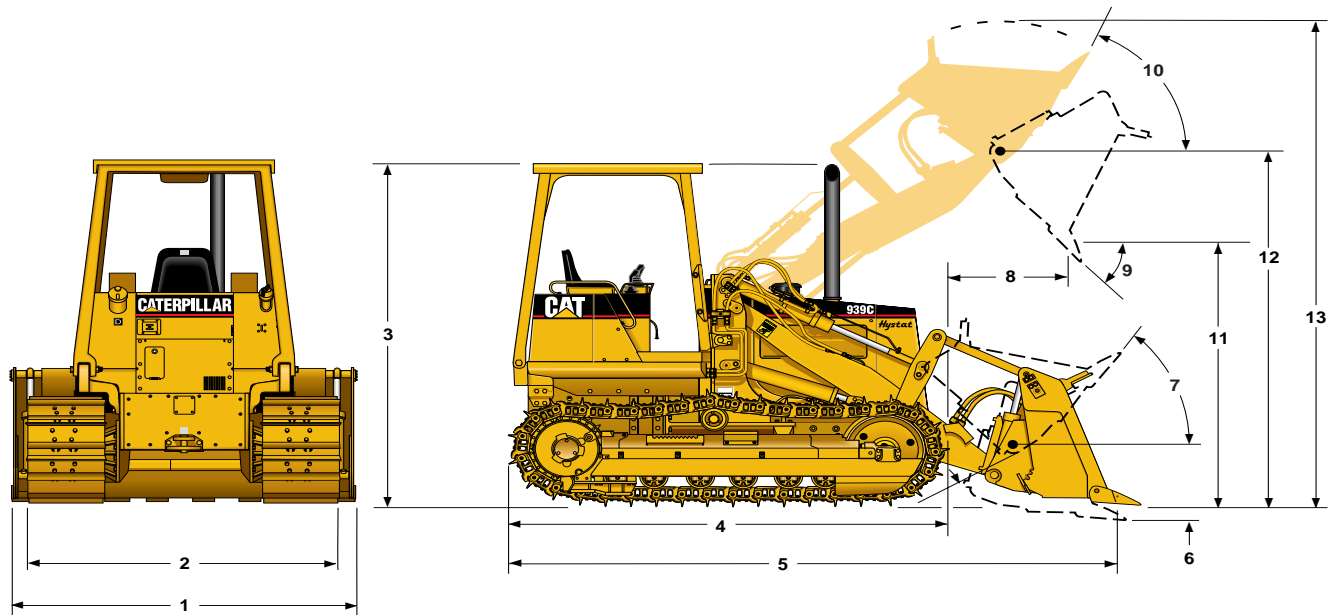

Dimensions (equipped with GP bucket)

Standard

1	Overall machine width with bucket	2160mm 85 in
2	Overall machine width without bucket	1955 mm 77 in
3	Machine height to top of cab	2766 mm 109 in
4	Length to front of track	2978 mm 117 in
5	Overall machine length	4359 mm 171.6 in
6	Digging Depth	127 mm 5 in
7	Maximum rollback at carry position	50.2°
8	Reach at full lift height	866 mm 34 in
9	S.A.E. specified dump angle	45°
10	Maximum rollback, fully raised	64.9°
11	Dump clearance at full height and 45° discharge	2677 mm 105 in
12	Height to bucket hinge pin	3346 mm 131.7 in
13	Overall machine height, bucket fully raised	4384 mm 172.6 in
14	Ground clearance	368 mm 14.5 in
15	Grouser height	37 mm 1.45 in

Operation Specifications

		GP Bucket	MP Bucket
		Bare	Bare
Rated Bucket capacity ^β (Nominal Heaped)	m ³	1.15	1.15
	yd ³	1.5	1.5
Struck Capacity ^β	m ³	0.95	0.95
	yd ³	1.25	1.25
Bucket Width	mm	2160	2160
	in	85	85
Dump Clearance at full lift and 45 discharge ^β	mm	2667	2604
	in	105	102.5
Reach at full lift and 45 discharge ^β	mm	866	877
	in	34.1	34.5
Digging depth ^β	mm	127	165
	in	5.0	6.5
Overall machine length	mm	4359	4359
	in	171.6	171.6
Overall machine height with bucket at full raise	mm	4384	4384
	in	172.6	172.6
Static tipping load *	kg	6,607	6,396
	lb	14,565	14,100
Breakout force	kN	89.9	92.0
	lb	20,200	20,688
Operating weight **	kg	9,484	10,030
	lb	20,908	22,113

^β Specifications and ratings conform to all applicable standards recommended by the Society of Automotive Engineers. SAE Standard J732 FEB80 and SAE Standard J742 OCT79 govern loader ratings.

* Measured at operating weight with ROPS canopy.

** Includes coolant, lubricants, full fuel tank, ROPS cab, bucket, 75 kg/165 lb operator and recommended counterweight.

Machine stability can be affected by the addition of other attachments. Add or subtract the following to/from machine operating weight and static tipping load:

	Change in Operating Weight		Change In Static Tipping Load	
Cab, ROPS	+204 kg	+450 lb	+253 kg	+558 lb
Bucket teeth (long) & segments	+179 kg	+394 lb	-226 kg	-498 lb
Air Conditioner	+77 kg	+170 lb	+84 kg	+185 lb
18" shoes	+108 kg	+238 lb	+76 kg	+168 lb
Ripper with 3 teeth (includes removal of 650 lb. rear counterweight)	+13 kg	+29 lb	+48 kg	+106 lb
Rear counterweight (per plate)	+116 kg	+255 lb	+195 kg	+430 lb

Standard Equipment

Standard and optional equipment may vary. Consult your Caterpillar dealer for specifications.

Air-to-oil transmission cooler	Indicator lights:	Precleaner
Air cleaner, dry-type with restriction indicator	Low alternator voltage	Pull hook, front
Alternator, 55-amp	Transmission/hydraulic oil filter restriction	Retrieval hitch, rear
Arm rests, four-way adjustable	Parking brake	Seat, vinyl, suspension with adjustable backrest and 3" seat belt
Automatic bucket positioner and lift kick out	Rabbit speed selection	Segmented sprockets
Battery, 12-volt, maintenance free, 900 cca with disconnect switch	Glow plugs	Service hour meter
Blower fan	Guards, bottom	Tool box with hinged lid
Cat 3046, turbocharged 6 cylinder diesel engine with 12-volt direct electric key start/stop	Guards, recoil, full length with sprocket guards and wipers	Track:
Engine enclosures, with grip handle	Horn	Adjusters, hydraulic
Fuel/water separator	Hydraulic controls, two-valve, single-lever bucket control	Front/rear guiding guards
Fuel priming pump	Hydraulic implement pump	Roller frames, six roller
Foot rests, adjustable	Hydrostatic transmission, dual path, closed loop	Sealed and Lubricated, two-piece master links
Gauges, illuminated, dash mounted showing engine coolant temperature, engine oil pressure, transmission oil temperature, and fuel level	Joystick control lever	Track shoes:
	Lifetime lubricated rollers and idlers	Standard — Sealed and lubricated double grouser 37-section, 406 mm (16")
	Muffler	Vandalism protection
	Parking brake - automatic	

Optional Equipment

Optional equipment may vary. Consult your Caterpillar dealer for specifics. Approximate changes in operating weights.

	kg	lb
Air conditioning, cab	66	146
Back up alarm (required in U.S.A.)	*	*
Batteries, 12-volt, heavy duty, maintenance free, two 900 cca with disconnect switch	30	65
Buckets:		
General Purpose: 1.2 m ³ (1.5 yd ³)	*	*
Multi-purpose: 1.2 m ³ (1.5 yd ³)	*	*
Bucket cutting edge, bolt-on:		
3-piece for GP and MP buckets	143	315
7-piece for use with bucket teeth	73	161
Bucket teeth, short, bolt-on:		
Set of 8 for GP and MP buckets	97	213
Bucket teeth, long, bolt-on:		
Set of 8 for GP and MP buckets	100	221
Cab, ROPS and mounting, includes 90-amp alternator, air pressurizer, air filter, heater, front and rear windshield wipers and washers, rearview mirror, sunvisor, speakers and antenna, ashtray, cigarette lighter, coat hook and key lock	204	450
Canopy, ROPS and mounting, includes rearview mirror and headliner (required in U.S.A.)	*	*

* Included in operating weight.

Available Rear Counterweights

To provide optimum performance for each machine configuration, 9 counterweight options are available ranging from 217 lb (99 kg) to 1870 lb (849 kg).

	kg	lb
Ether start aid	4	9
Guards:		
Bottom, heavy duty	58	128
Rock, idler	45	110
Roller, full length	67	148
Heater, open canopy	36	80
Hydraulic arrangement:		
3-valve, 1-lever bucket control MP bucket	16	36
3-valve, 1-lever bucket control, ripper	10	21
4-valve, 1-lever bucket control MP bucket, ripper	25	56
Lights, ROPS mounted, two front, one rear	15	32
Pre-cleaner with pre-screener	1	2
Ripper, includes three teeth and hydraulic cylinder	249	549
Ripper teeth, additional	12	26
Screens:		
Rear, for use w/ROPS canopy	30	66
Rear, for use w/ROPS cab w/o air conditioning	31	69
Rear, for use w/ROPS cab with air conditioning	24	53
Side	50	111
Seat, Caterpillar Contour Series with adjustable backrest and 3" retractable seat belt	28	62
Sweeps, logging	78	172
Tracks: double grouser:		
Sealed and Lubricated, 37-section, 457 mm (18") shoes	108	238

Complete Versatility

From the beginning of a job to the finish grading, the 939C Hystat Track-Type Loader is a versatile tool.



One machine for all jobs!

Some of the first steps on any job can be accomplished easily with the help of the 939C, beginning with clearing the job site by loading and carrying debris, as shown above. Excavating and carrying/spreading material, above right, are also crucial elements to any job. The 939C is the perfect tool to perform them. Rounding out the job, below right, the 939C greatly facilitates trash cleanup, loading, and finish grading work.



939C Hystat Track-Type Loaders



Your Cat Dealer

There is one very important component included with every Caterpillar 939C Hystat Track-Type Loader that no one else can offer: your Cat dealer.

Whether you have questions about performance, service or financing, your Cat dealer has the answers. He is dedicated to helping you make the right equipment choice for your requirements.

Plus, your Cat dealer has most parts you will ever need for your Cat equipment right on the shelf. If not, the dealer's worldwide computerized network will immediately find the closest location of the part you need, minimizing your downtime.

When you need more details about the 939C, contact your Cat dealer. You'll find he's easy to talk to. And he's genuinely interested in talking with you.

AEHQ3870-03 (1/00)
(Replaces AEHQ3870-02)

© 2000 Caterpillar
Printed in U.S.A.

Materials and specifications are subject to change without notice.
Featured machines in photos may include additional equipment.
See your Caterpillar dealer for available options.

CATERPILLAR[®]