

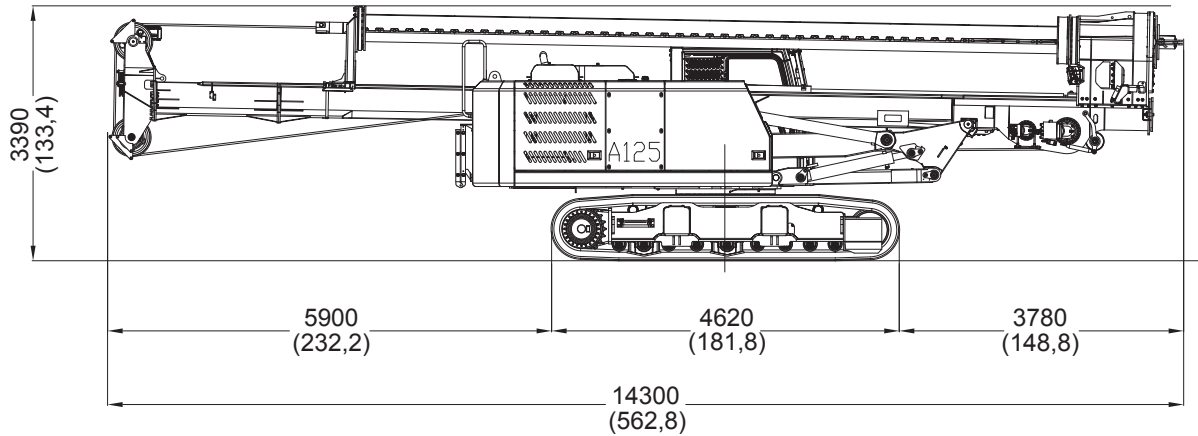

A 125

Powered by CAT



Base		IMT
Undercarriage length / widening range / shoe	mm	CAT 4620/2550 - 3650/600
	in	182/100 - 144/23,6
Engine type		CAT C 6.6 Acert
Power		120KW (163 HP) @1800 rpm
Rotary		
Installed torque	kNm	122
	lbf ft	90000
Working speed	rpm	7,5 - 27
Discharge speed	rpm	45 - 120
Winches		
Main winch pull force	kN	123
	lbf	27655
Main winch speed	m/min	90
	ft/min	295
Main winch Cable diameter	mm	22
	in	/
Auxiliary winch pull force	kN	60
	lbf	13490
Auxiliary winch Speed	m/min	90
	ft/min	295
Auxiliary winch Cable diameter	mm	15
	in	/
Crowd system		
Kelly crowd push	kN	100
	lbf	22485
Kelly crowd pull	kN	165
	lbf	37095
Stroke	mm	3325
	in	131
Mast		
Mast raking forward		5°
Mast side raking		+5°
Mast raking backwards		15°
Pile max. diameter	mm	1500
	in	60
Kelly bar		
Standard		4/38
Options available		4/34 - 5/47
Operating Weight w/standard kelly bar	t	36
	lbs	79370

Measurements in working phase

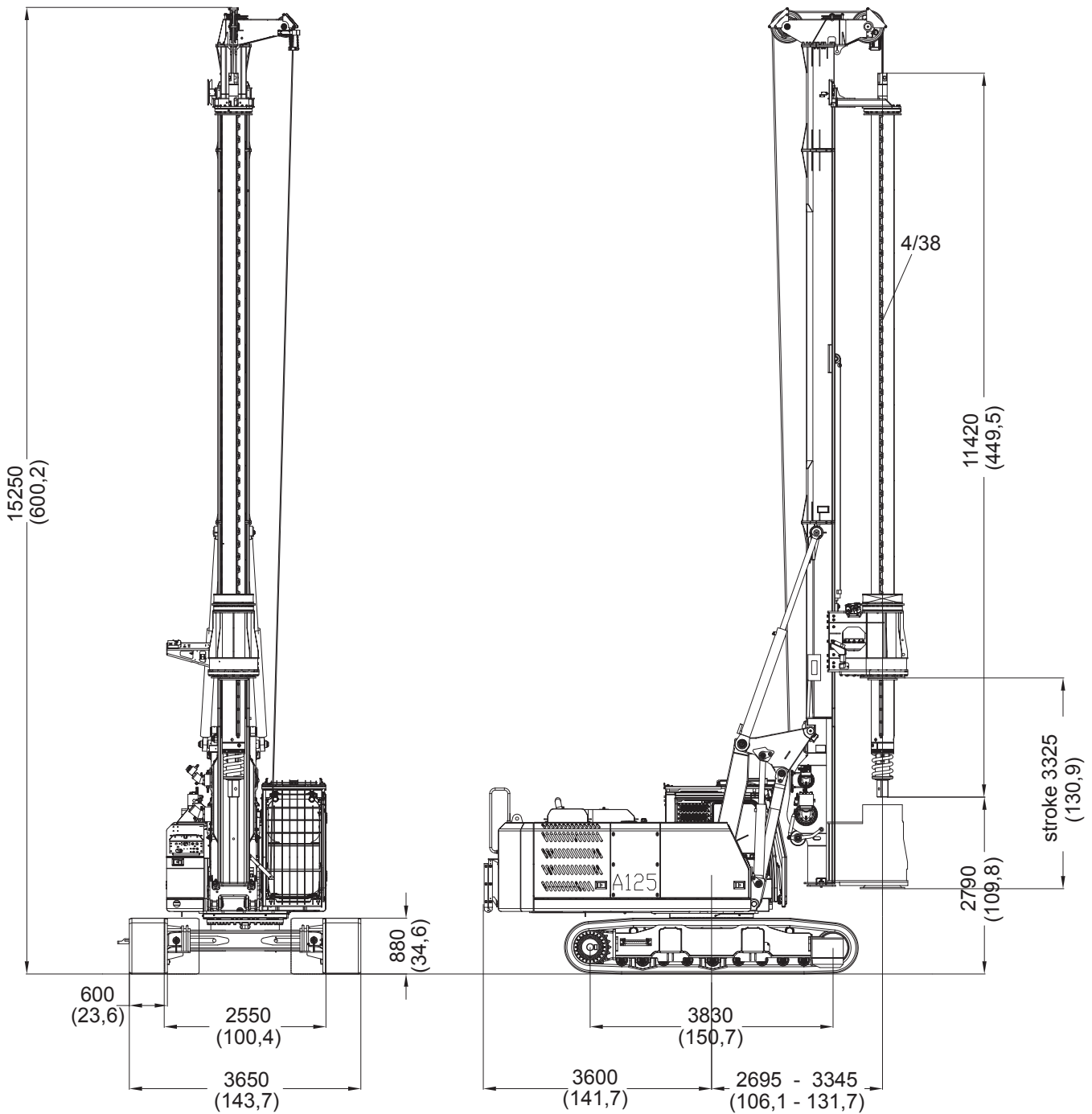

Purpose built Foundation Drilling Rig developed in cooperation with Caterpillar OEM Solutions Group



Via d'Ancona, 39 - 60027 Osimo (An) - Italy
Tel. + 39 071 723341 r.a. - Fax + 39 071 7133352
www.imtspa.com - imt@imtspa.com

All technical data are purely indicative and subject to change without notice.