

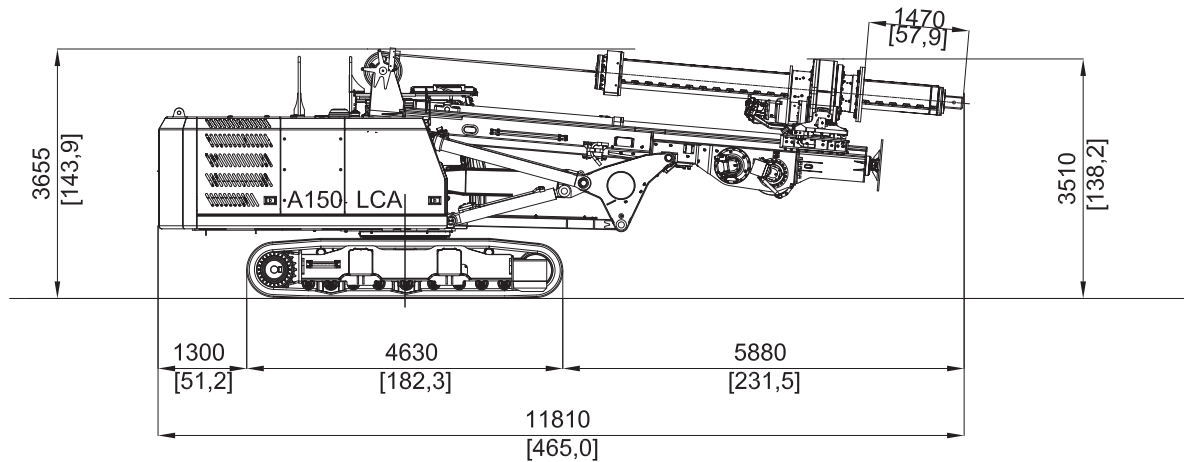

A 150 LCA Powered by CAT



Base

Undercarriage length / widening range / shoe	mm	IMT CAT 4630/2550 - 3650/650
	in	182/100 - 144/25,6
Engine type		CAT C 7.1 Acert
Power		162KW (217 HP) @1800 rpm

Rotary

Installed torque	kNm	160
	lbf ft	118010
Working speed	rpm	8-28
Discharge speed	rpm	40-110

Winches

Main winch pull force	kN	155
	lbf	34850
Main winch speed	m/min	80
	ft/min	262
Main winch Cable diameter	mm	24
	in	/
Auxiliary winch pull force	kN	75
	lbf	16865
Auxiliary winch Speed	m/min	75
	ft/min	246
Auxiliary winch Cable diameter	mm	18
	in	/

Crowd system

Kelly crowd push	kN	160
	lbf	35970
Kelly crowd pull	kN	200
	lbf	44965
Stroke	mm	2300
	in	91

Mast

Mast raking forward		5°
Mast side raking		+5°
Mast raking backwards		15°
Pile max. diameter	mm	1600
	in	63

Kelly bar

Standard		5/20
Options available		
Operating Weight w 5/20 kelly bar	t	43
	lbs	94800
Operating Weight w/o 5/20 kelly bar	t	40
	lbs	88190

Measurements in working phase

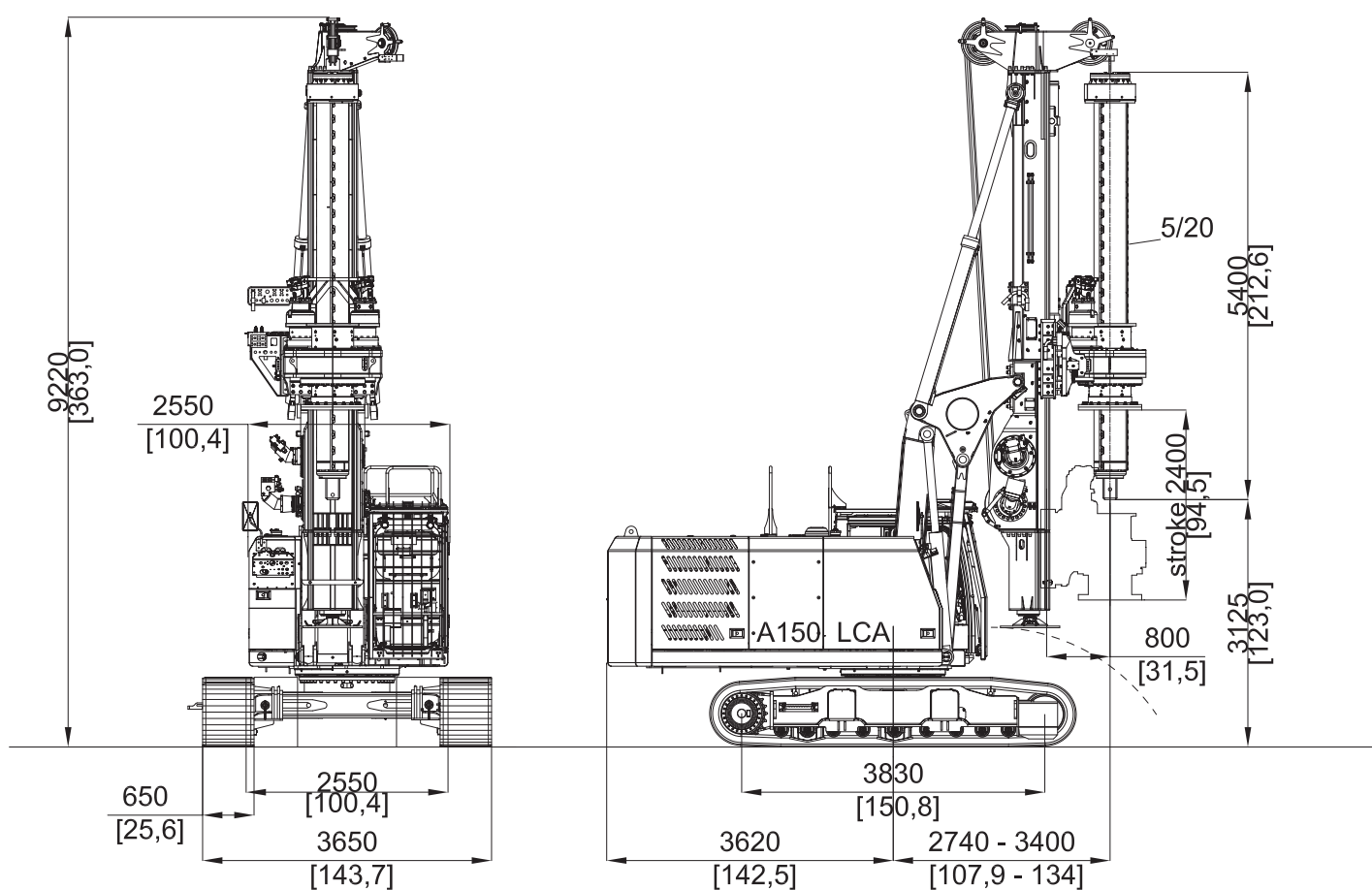

Purpose built Foundation Drilling Rig developed in cooperation with Caterpillar OEM Solutions Group



Via d'Ancona, 39 - 60027 Osimo (An) - Italy
Tel. + 39 071 723341 r.a. - Fax + 39 071 7133352
www.imtspa.com - imt@imtspa.com

All technical data are purely indicative and subject to change without notice.