

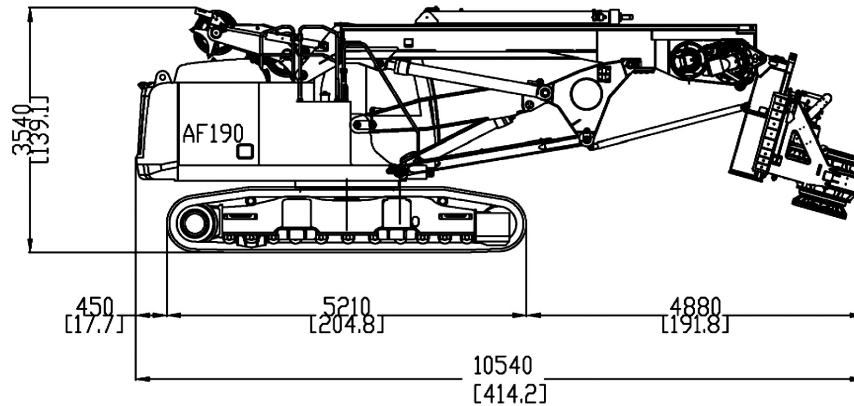

AF 190E LCA Powered by CAT



Base		Caterpillar 329E
Undercarriage length / widening range / shoe	mm	CAT 5210/2900 - 4200/700
	in	205/114 - 165,3/27,5
Engine type		CAT C 7.1
Power		181 KW (245 HP) @1800 rpm
Rotary		
Nominal torque	kNm	205
	lbf ft	151205
Working speed	rpm	7 - 27
Discharge speed	rpm	40 - 110
Winches		
Main winch pull force	kN	200
	lbf	44965
Main winch speed	m/min	85
	ft/min	279
Main winch Cable diameter	mm	26
	in	/
Auxiliary winch pull force	kN	80
	lbf	17985
Auxiliary winch Speed	m/min	85
	ft/min	279
Auxiliary winch Cable diameter	mm	18
	in	/
Crowd system		
Kelly crowd push	kN	180
	lbf	40470
Kelly crowd pull	kN	200
	lbf	44965
Stroke	mm	1860
	in	73
Mast		
Mast raking forward		5°
Mast side raking		+ 8°
Mast raking backwards		15°
Pile max. diameter	mm	1800
	in	71
Kelly bar		
Standard		4/20
Options available		4/15 - 4/17
Operating Weight w/standard kelly bar	t (metric)	48,5
	lbs	106925

Measurements in working phase

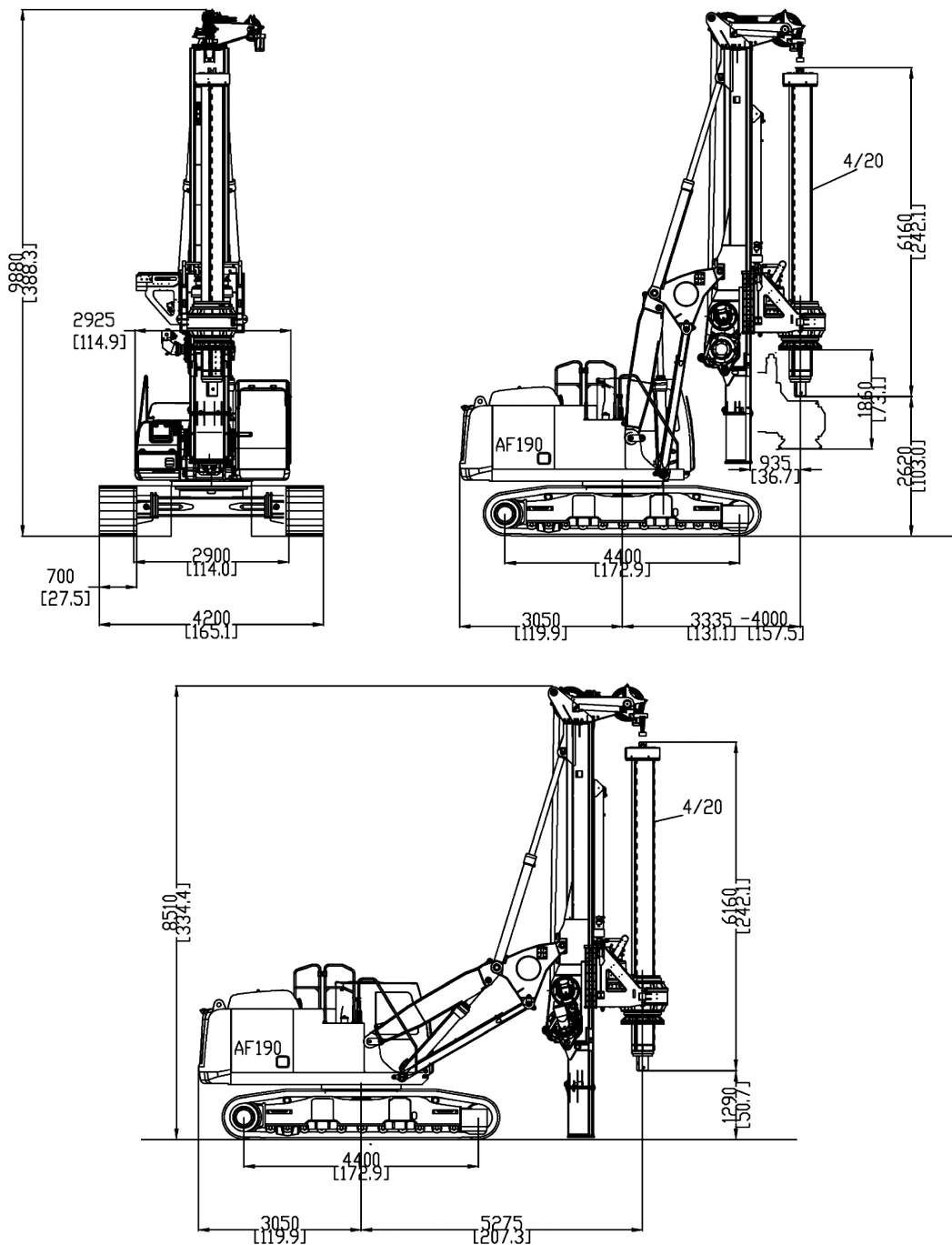

Purpose built Foundation Drilling Rig developed in cooperation with Caterpillar OEM Solutions Group

IMT
INTERNATIONAL

Legal Headquarters:

Via dei Gracchi, 91 - 00192 Roma Italy

Offices and Plant:

Via d'Ancona, 39 - 60027 Osimo (An) - Italy

Tel. + 39 071 723341 r.a. - Fax + 39 071 7133352

www.imtspa.com - imt@imtspa.com

All technical data are purely indicative and subject to change without notice.