

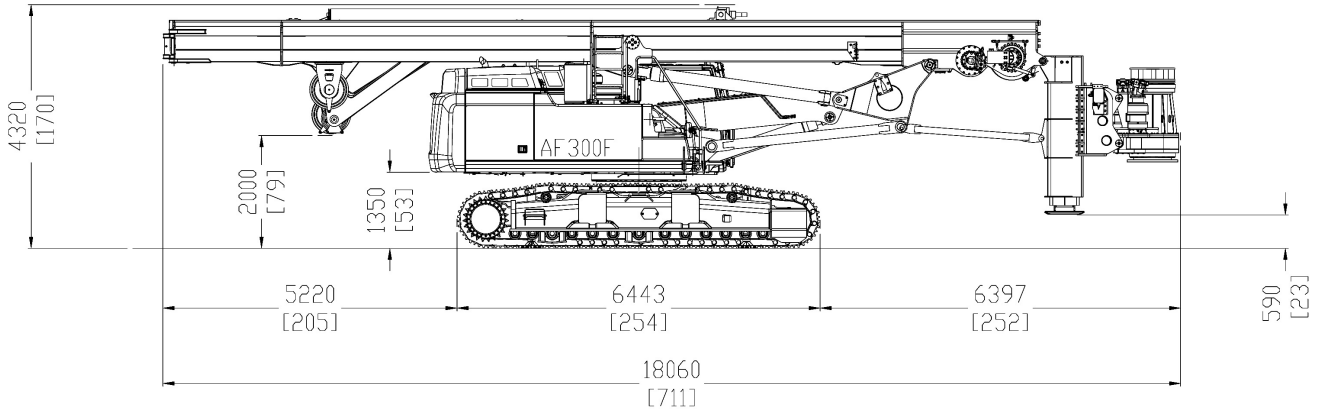

AF 300 F

Powered by CAT



Base		CAT 352 F
Undercarriage length / widening range / shoe	mm	CAT 6440/3500 - 5000/900
	in	253/137 - 197/35,4
Engine type		CAT C13 Acert Tier4F
Power		322 KW (432 HP) @ 1800 rpm
Rotary		
Installed torque	kNm	310
	lbf ft	228645
Working speed	rpm	6,5 - 28
Discharge speed	rpm	45 - 110
Winches		
Main winch pull force	kN	300
	lbf	67445
Main winch speed	m/min	70
	ft/min	230
Main winch Cable diameter	mm	32
	in	/
Auxiliary winch pull force	kN	150
	lbf	33725
Auxiliary winch Speed	m/min	80
	ft/min	262
Auxiliary winch Cable diameter	mm	20
	in	/
Crowd system		
Kelly crowd push	kN	350
	lbf	78685
Kelly crowd pull	kN	390
	lbf	87680
Stroke	mm	6536
	in	257
Mast		
Mast raking forward		5°
Mast side raking		+5,5°
Mast raking backwards		15°
Pile max. diameter	mm	2500
	in	99
Kelly bar		
Standard		4/46
Options available		3/35 - 4/50 - 5/64 - 6/75
Operating Weight w/standard kelly bar	t (metric)	100
	lbs	220460

