

## A 150 - Hydraulic Drill Rig

Crowd cylinder version

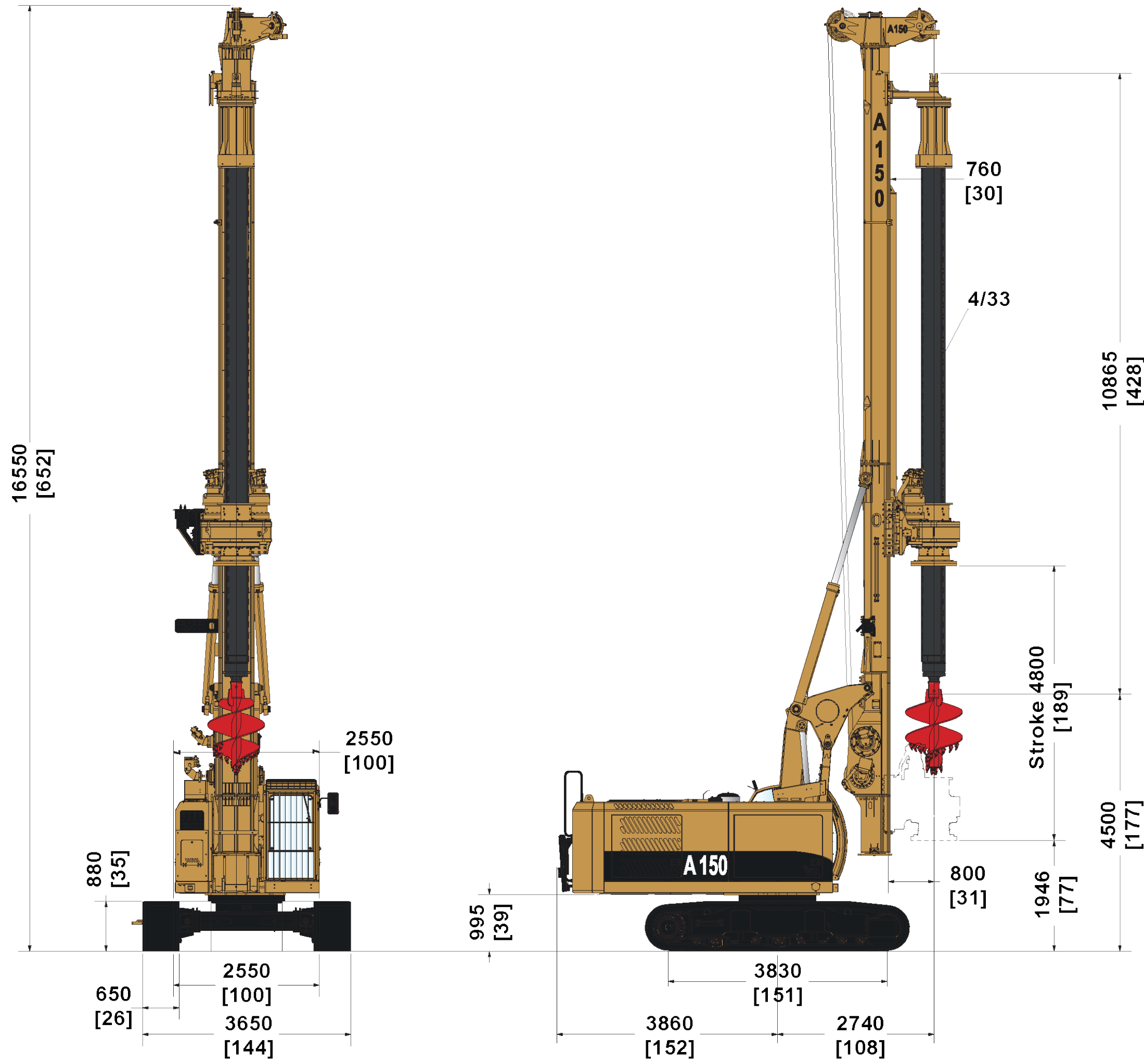

LCA version

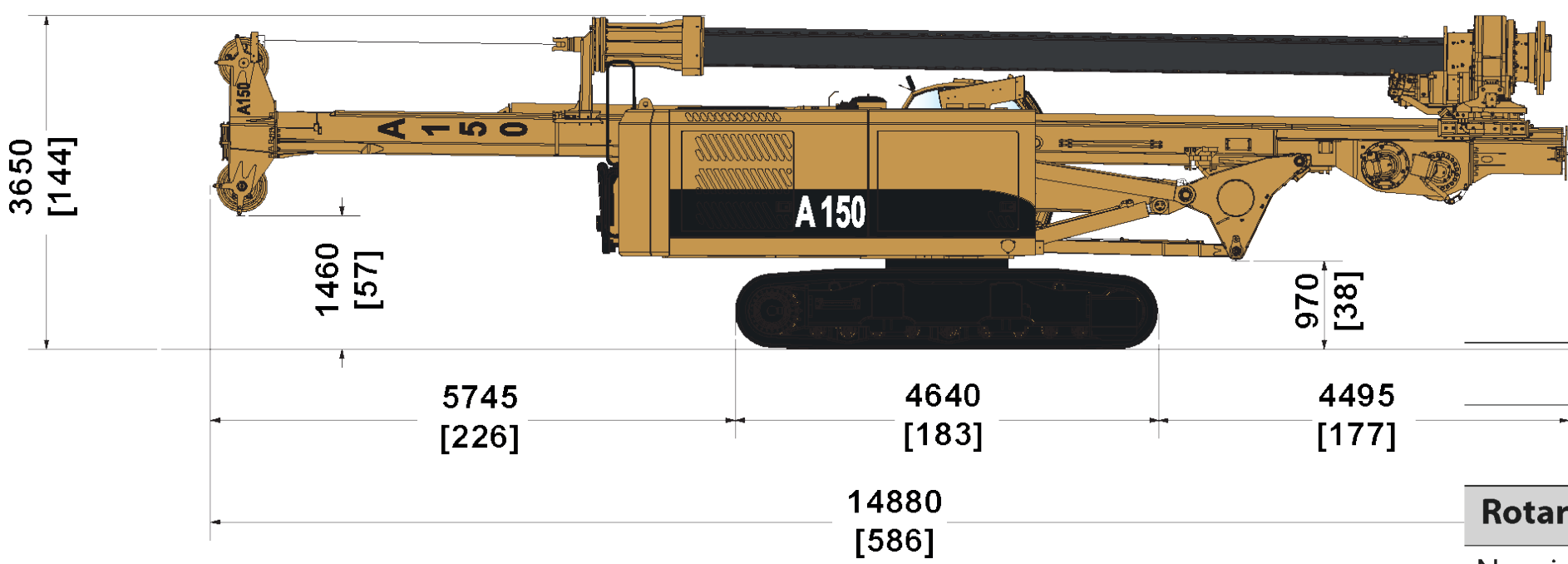
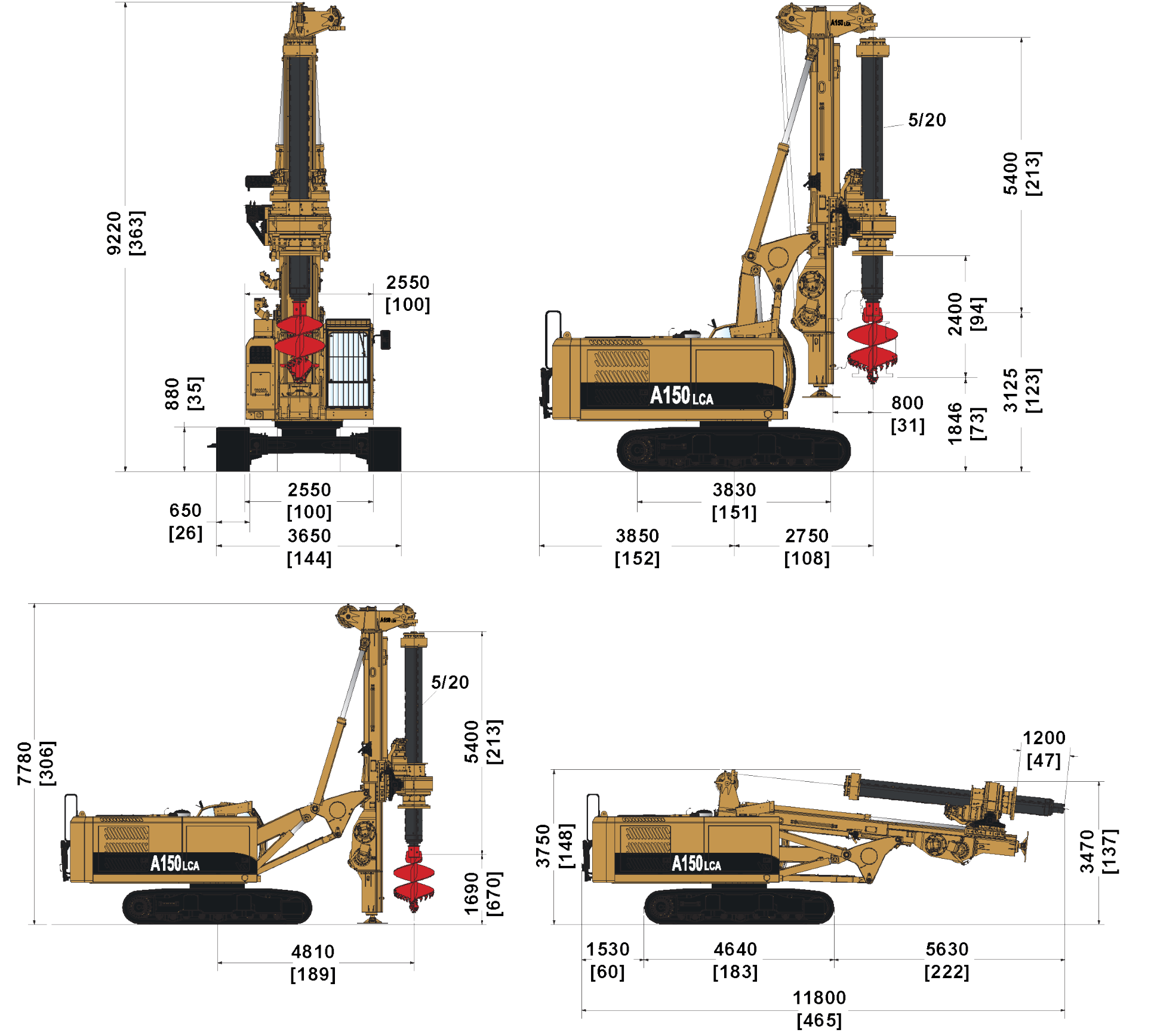

### Technical specifications

A150 Tier 4 Final

Rotary		
Nominal torque	kNm	160
	lbf ft	118010
Min. Working speed	rpm	8
Max. Working speed	rpm	28
Min. Discharge speed	rpm	40
Max. Discharge speed	rpm	110

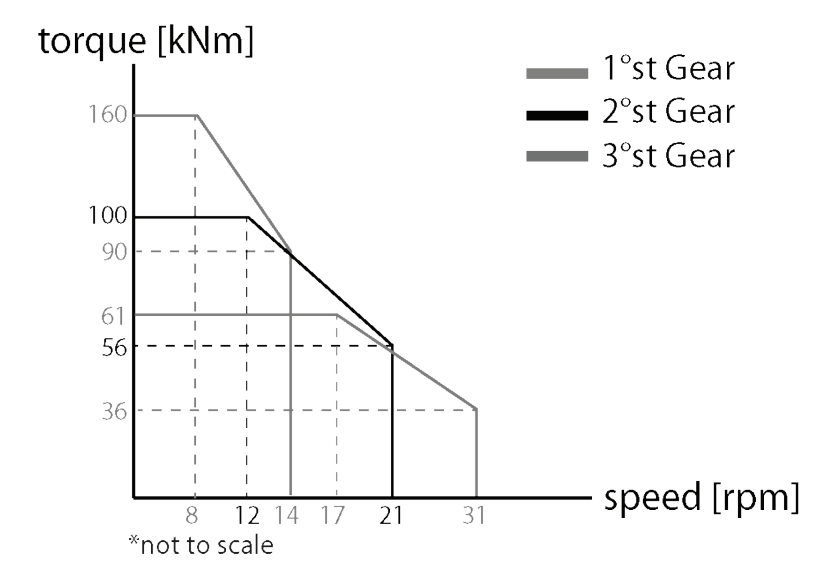

Winches		
Main winch pull force	kN	155
	lbf	34850
Main winch speed	m/min	80
	ft/min	262
	in	/
Auxiliary winch pull force	kN	75
	lbf	16865
Auxiliary winch speed	m/min	75
	ft/min	246

Crowd System		
Kelly crowd push	kN	160
	lbf	35970
Kelly crowd pull	kN	200
	lbf	44965
Stroke (mm)	mm	4800
	in	189

Base		
IMT		
Undercarriage length / widening range / shoe	mm	CAT 4640 / 2550 - 3650 / 650
	in	182 / 100 - 144 / 25,6
Engine type	CAT C7.1 Tier 4F	
	169 KW (227 HP) @1900 rpm	

Kelly bar		
Standard		4/33
Options available		4/25 - 5/42
Operating Weight w/standard kelly bar	t (metric)	46,75
	lbs	103070
Operating Weight w/o standard kelly bar	t (metric)	40,5
	lbs	89290

### Removable parts for transport phase

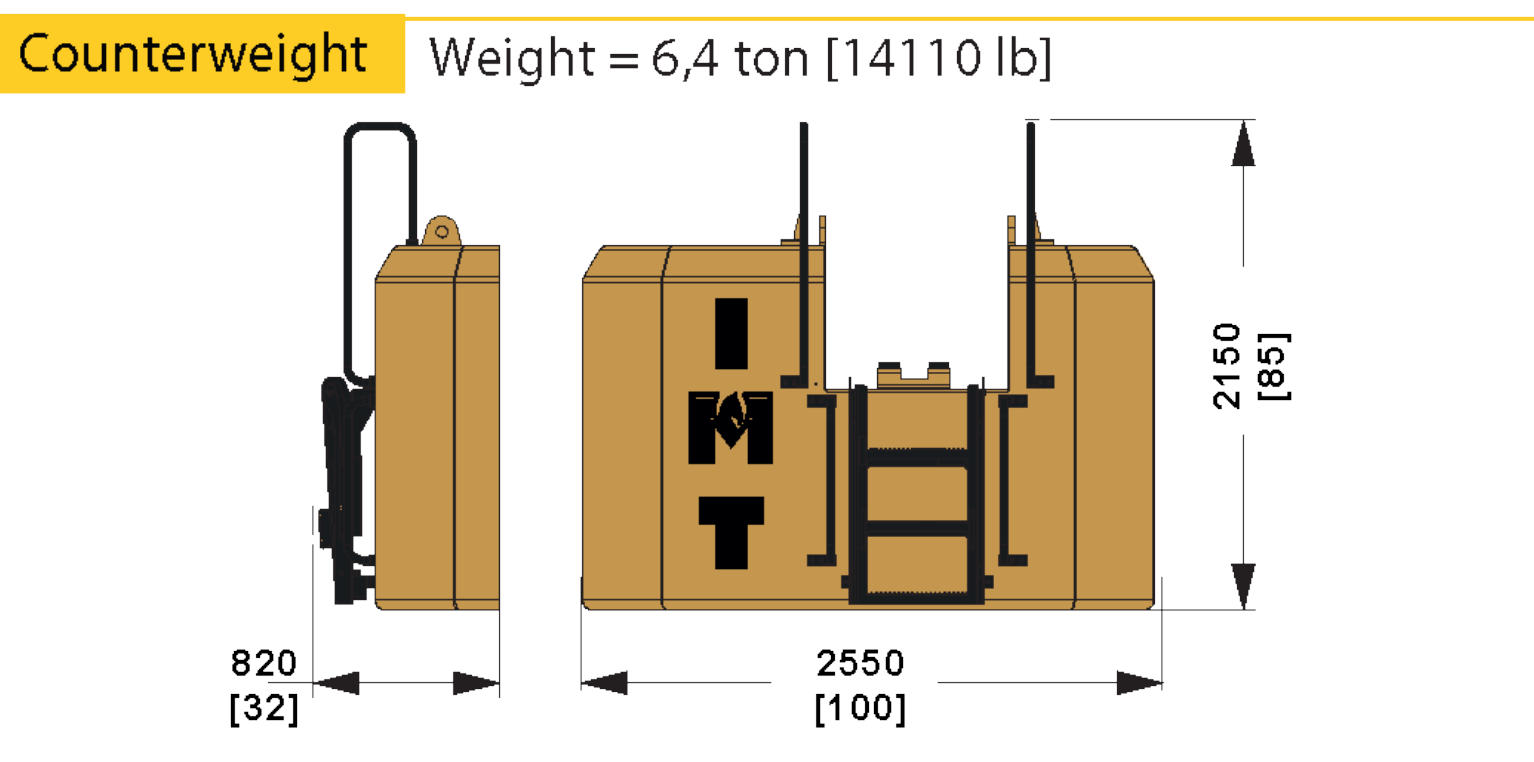
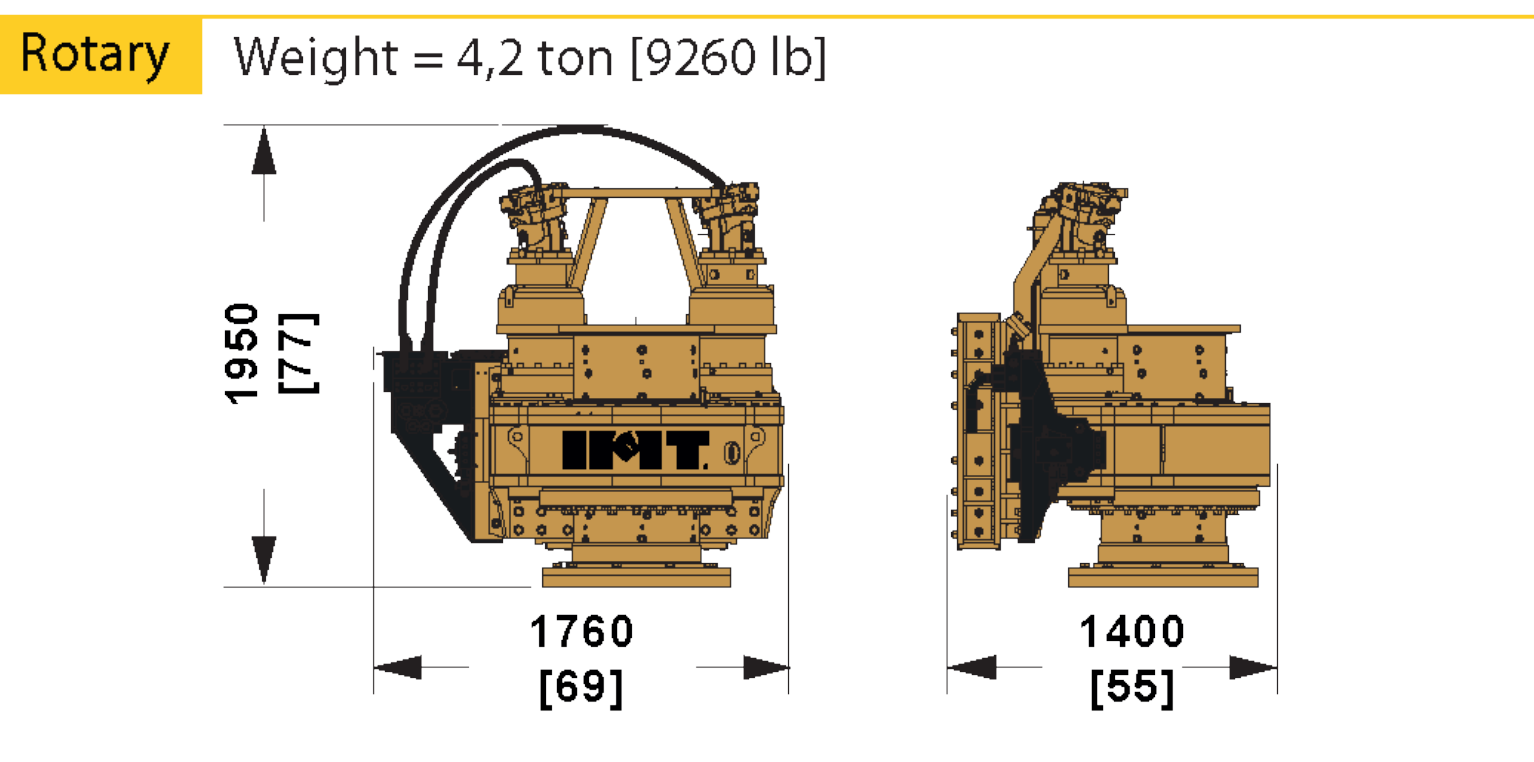

A150 Lca Tier 4 Final

Crowd System		
Stroke (mm)	mm	2400
	in	94
Kelly bar		
Standard		5/20
Options available		
Operating Weight w/standard kelly bar	t (metric)	43,05
	lbs	94910
Operating Weight w/o standard kelly bar	t (metric)	39,8
	lbs	87750